

# MAXWELL

Magazine of the Electrotechnische Vereeniging

## Controlling the brain Graduation report

## Nuna5 What went wrong?

## Avionics The main contributor to innovation in aviation



Edition 13.3  
Alumni edition

April 2010

**HIER INVOEGEN:  
PAGINA2NEN.PDF**



The Board with the delicious cream pie

## From the Board

You find in your possession this year's alumni edition of Maxwell. This is an extra thick edition of our quarterly magazine, which we are quite proud of. It represents an important method for us to stay in contact with graduated electrical engineers. This contact is important to us, as we aim to give people the opportunity to broaden their view on their field of study and provide information about jobs and companies that could be interesting to them. Henceforth, if you know an electrical engineer with an interesting position, or if you would like to share your own experiences, please don't hesitate to contact us.

To follow, this quarter we made sure that aspiring electrical engineers got a chance to open their minds to a wide variety of new ideas and projects. We went to CeBit in Hannover, went on an excursion to Shell in Moerdijk, where we visited their chemical plant, and received a lunch lecture from Technolution. But of course, visiting companies is not the only way to broaden your view on our profession. One big thing we are working on at the moment is the organisation of the EESTEC exchange. The European organisation EESTEC has the aim to bring electrical engineering students from all over Europe together to give them the opportunity to experience foreign cultures. In June there will be an exchange to Delft, which a committee of the ETV will organise. To coordinate the activities of the EESTEC organization all members meet once a year at a congress to speak about the plans for the organization for next year, to elect a new EESTEC board and to sort out the financial affairs of the organization. This year this congress took place in Athens where Delft was represented by two Board members of the ETV, Frank Teunisse and Jan Christiaanse. They had a great week and gave a lot of useful input on the meetings.

That same week it was the ETV's Dies. On the 23rd of March we had a huge home-made pie in the faculty hall. It took two full days to make, but it was worth all the trouble. The pie was absolutely delicious.

Aside from all the activities the Board also visits the honoree members of the association. The ETV has 12 honoree members. These people are usually visited once a year by the Board of the ETV. We have heard a lot of stories about their careers and experiences, what it was like to be a student and how they have been keeping themselves busy.

But most of the time you can find us in the Board room of the ETV. So if you like to meet some other students in a relaxed atmosphere, just drop along for a free cup of coffee.

On behalf of the inviting Board,  
Imke Zimmerling, President



Jan and Frank in Athens



The Board visiting honoree member De Kroes

# Editorial

Although every single edition of the Maxwell on its own is special, once a year the entire Maxwell Committee prepares itself for her yearly magnum opus. By reading this, you've reached the fourth page of the Alumni edition of already the thirteenth year of the Maxwell. For the committee the alumni edition always provides an extra challenge, as it contains more pages to fill with interesting content than a regular edition.

What to expect of this Maxwell? Besides the usual sections like the From the Board, the news-flash and an overview of the recent activities of the Electrotechnische Vereeniging, the Maxwell Committee tried to provide you with an article about every branch of Electrical Engineering. From the Telecommunications angle an article about the communication network of the Dutch emergency services C2000 is presented. Marijn van Dongen provides a report about his master thesis work, by which also Microelectronics is represented. An insight in the development in the powering of trams is given by Professor van der Sluis from Power Engineering. Last, some Computer Engineering topics are touched upon by two different companies. The Austrian company TTTech explains its adaptation of the existing Ethernet. The Dutch Technolution explained how difficult it is to use the GPU for other processing tasks.

To conclude, I expect that you will have some pleasant hours reading this edition of the Maxwell. For any remarks, complaints or other comments, please feel free to contact the Maxwell Committee.

Stephan Groot

# Contents



Controlling the brain  ○

○ Avionics 



ETVMAGAZINE "MAXWELL" Year 13 - edition 3 - April 2010 PRINTING ThiemeMediaServices, Delft NUMBER OF COPIES 5500 EDITORS Ben Allen, Joost van Driel, Benjamin Gardiner, Stephan Groot, Maarten Kastelein, Jeroen Ouweneel, Imke Zimmerling CONTACT Maxwell, p/a Electrotechnische Vereeniging, Mekelweg 4, 2628 CD Delft, phone: 015-2786189 or 015-2781989, fax: 015-27 81002, e-mail: [maxwell@etv.tudelft.nl](mailto:maxwell@etv.tudelft.nl), website: [www.etv.tudelft.nl](http://www.etv.tudelft.nl) CHANGE OF ADDRESS Please send your changes to the address above, or use the website. Alumni can change their address via the Alumni Office website: [www.alumni.tudelft.nl](http://www.alumni.tudelft.nl). ADVERTISEMENTS ASML (p.47), Farnell (p.48), Mastervolt (p.29), Navigon (p.35), NEN (p.2), Pinewood (p.35), Smit (p.15), Technolution (p.45), TNO (p.21) SUBSCRIPTIONS Non-members can receive the Maxwell four times a year, against a contribution of €10,- per year. For more information, please contact the Maxwell Committee.

**C2000: Life-saving communication?** 

# 26



**Innovatie in trammetjesland** 



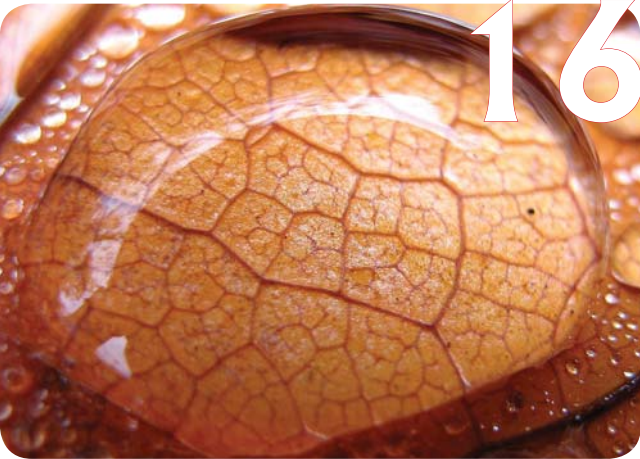



# 16



**NuNa 5: What went wrong?** 



# 36

- From the board  3
- Newsflash  6
- Educational announcements  8
- FSR  8
- Activities of the ETV  9
- Cooking with: Rob Remis  28
- TTEthernet  30

- Joost may know it  34
- Circuit  38
- Per elektrische scooter naar Kopenhagen  40
- Gadgets  42
- Technolution: GPU  43
- Column: Prof. Ligthart  46

# Newsflash

## MIT makes display with flying pixels

Imagine that pixels could fly out of your computer screen and create an immersive, luminous cloud capable of displaying digital information in three-dimensional space. This is the vision beyond Flyfire, a new project put together by researchers at MIT's SENSEable City Lab and Aerospace Robotics and Embedded Systems Laboratory (ARES Lab). Flyfire uses a large number of remotely controlled, self-organizing "micro helicopters". Each helicopter contains small LEDs and acts as a smart pixel. Through digitally controlled movements, the helicopters perform elaborate and synchronized choreographies, generating a unique free-form display in three-dimensional space.

Using the self-stabilizing and precise controlling technology developed by the ARES Lab, the motion of the pixels is adaptable in real time. The Flyfire canvas can transform itself from one shape to another or bring a two-dimensional photographic image into an articulated shape (background image). "Today we are able to simultaneously control a handful of micro helicopters, but with Flyfire we are aiming to scale up and reach very large numbers," said Emilio Frazzoli, head of the ARES Lab. "Flyfire opens up exciting possibilities: as on a conventional screen, pixels can change color, but now they can also move,

creating a transient trace of light in three-dimensional space," said team member Carnaven Chiu. "Unlike traditional displays that can only be seen from the front, Flyfire becomes a three dimensional immersive display that can be experienced from all directions." Flyfire is conceived as a public space installation, in which the pixels recharge every few minutes and then perform in space. "In general, there are two ways to increase the resolution of a display," said Carlo Ratti, director of the SENSEable City Lab.

"One is to use smaller pixels. The other one is to look at it from farther away. Flyfire adopts the second approach to create a unique visual experience in large public spaces." Flyfire is made possible by recent advances in battery technology and wireless control. It aims to be a step towards 'smart dust', the idea that computing is becoming increasingly smaller, addressable, pervasive - and persuasive. The Flyfire project was developed by E. Roon Kang, Carnaven Chiu, Caitlin Zacharias, Shaocong Zhou, Assaf Biderman and Carlo Ratti of SENSEable City Lab in collaboration with Erich Mueller and Emilio Frazzoli of ARES Lab.

Source: <http://senseable.mit.edu/flyfire>

## Skinput: a touchscreen on your arm

Paul Marks, New Scientist

Finding the keypad on your cellphone or music player a bit cramped? Maybe your forearm could be more accommodating. It could become part of a skin-based interface that effectively turns your body into a touchscreen. Called Skinput, the system is a marriage of two technologies: the ability to detect the ultralow-frequency sound produced by tapping the skin with a finger, and the microchip-sized "pico" projectors now found in some cellphones.

The system beams a keyboard or menu onto the user's forearm and hand from a projector housed in an armband. An acoustic detector, also in the armband, then calculates which part of the display you want to activate. But how does the system know which icon, button or finger you tapped? Chris Harrison at Carnegie Mellon University in Pittsburgh, Pennsylvania, working with Dan Morris and Desney Tan at Microsoft's research lab in Redmond, Washington, exploit the way our skin, musculature and

skeleton combine to make distinctive sounds when we tap on different parts of the arm, palm, fingers and thumb.

They have identified various locations on the forearm and hand that produce characteristic acoustic patterns when tapped. The acoustic detector in the armband contains five piezoelectric cantilevers, each weighted to respond to certain bands of sound frequencies. Different combinations of the sensors are activated to differing degrees depending on where the arm is tapped.

Twenty volunteers tested the system and most found it easy to navigate through icons on the forearm and tap fingers to actuate commands. Skinput works very well for a series of gestures, even when the body is in motion, the researchers say, with subjects able to scroll through menus whether they moved up and down or flicked across their arm. The system could use wireless technology like Bluetooth to transmit commands to many types of devices. The researchers will present their work in April at the ACM Computer-Human Interaction meeting in Atlanta, Georgia.



Figure 1: The Skinput-system projecting buttons on an arm.

## Record communication speeds over ceiling lights

Researchers at Fraunhofer Heinrich Hertz Institute in Berlin together with their Siemens colleagues have scored a peak data rate of 500 megabits per second (Mbit/s) using off-the-shelf LED lights. The new benchmark breaks the previous record they held of 200 Mbit/s. Data transport over visible light is a means of transmission that is license-free, and tap-proof and that opens the way for a range of novel applications in the home, industry and transport.

Researchers at Siemens Corporate Technology in Munich and the Heinrich Hertz Institute set the new free space data transmission record for a distance of up to 5 meters using a white light emitting diode from the Siemens subsidiary Osram. Data were directly modulated from the supply current onto the quantity of light emitted by the LED. The Ostar LED used is one of the brightest now on the market and can be modulated so rapidly that a highspeed data transmission rate of 500 Mbit/s can be achieved while the human eye detects no change in the level of brightness. The receiver is a photodetector that transforms light signals into electrical impulses.

Visible Light Communication (VLC) is a medium that holds out the promise of a wide range of applications. In the home

## Babbage nanomachine promises low-energy computing

Not only did Charles Babbage lay the foundations for the computer revolution, his designs for mechanical computers also provide a blueprint for energy efficiency. So say Raj Mohanty of Boston University and his colleagues, who have created a nanoscale mechanical logic gate that could form the basis of tiny mechanical computers.

The gate consists of a strip of silicon 300 nanometres wide sitting between two chunks of silicon. Applying a voltage between one chunk and the strip causes the strip to vibrate, like the reed in a clarinet. With the right voltage, the strip will enter a so-called hysteretic regime - where it will vibrate with one of two amplitudes.

"The two amplitude states are separated by a potential barrier," says Mohanty. By using a pair of electrical pulses that work with the resonating strip to provide that kick in potential, the team were able to flip the vibration from one amplitude to the

it can be a valuable extension to established WLAN technologies as in many buildings wireless networks are increasingly impeded by clogging of the three independent WLAN frequency bands which leads to collisions between data packets. As a license-free and previously unexploited medium, visible light offers a viable alternative. A further key advantage is that VLC also offers tap-proof secure lines as only the receiver located directly in the light cone can receive the transmitted data, thus precluding any "eavesdropping" on the light beam. In factories and medical technology there is a need for data transmission in places where wireless cannot be deployed or only to a limited

extent. Yet another area of application is in the transport domain where LED traffic lights and railway signals can relay information to cars and trains.

The researchers also demonstrated that a network of up to five LEDs is capable of achieving data transmission speeds of up to 100 Mbit/s over a

longer distance. This is a critical point for practical applications as, for instance, data from ceiling lights

can then be sent to a receiver on a desktop no matter where the desk is positioned in the room. Since 2007 the Institute of Electrical and Electronics Engineers (IEEE) has been working on standardization of the technology in a procedure scheduled for completion by late 2010.

Source: <http://www.hhi.fraunhofer.de>.

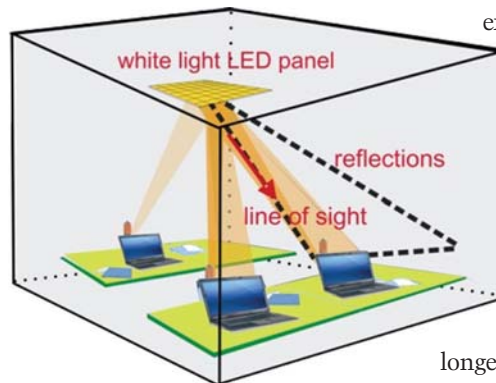

Figure 2: The principle of LED-light communication.

other. If just one of the pulses - or neither of them - resonates with the strip then it remains in its existing vibrational state. In other words, says Mohanty, the device acts as an AND logic gate (Nano Letters, DOI: 10.1021/nl9034175).

While the gate is not as fast as its traditional equivalent, it loses far less energy per operation, Mohanty claims. "When you have millions of devices on a chip, energy loss adds up," he says. Trading speed for energy might be beneficial in some situations.

Source: <http://www.newscientist.com/>

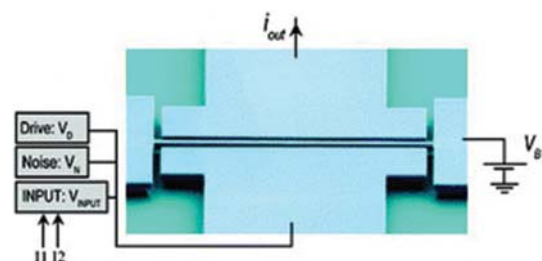

Figure 3: The new chip, with inputs and output.

# Educational Announcements

The faculty of Electrical Engineering, Mathematics and Computer Science is constantly undergoing evaluation and change. Here are the most important goings-on in our faculty at this moment.

**Author: Frank Teunisse, Commissioner of Education**

## MIGRATION TO OSIRIS

Osiris is now almost fully functional, and the migration of the ISPs is also almost finished. Starting next quarter, subscriptions for exams have to be done in Osiris. Furthermore, from now on there will be a single deadline for subscribing for all exams. For the fourth quarter, this deadline will be June 6<sup>th</sup>.

## STRESS ON THE THIRD FLOOR OF EWI

On the third floor people are working harder than ever. The Bachelor and Master Electrical Engineering and the Master Computer Engineering are about to be inspected. As such, our whole education system has to be evaluated. Furthermore, a new Bachelor program is in the pipeline. The plan is that upcoming freshmen will start with a study program that is much more project orientated.

## NEW TIMETABLE SOFTWARE IN BLACKBOARD

You can now create, store and view your personal timetable in blackboard. A group of enthusiastic Computer Science students were unhappy with the timetable site that was introduced last summer, and built a new, improved one. You can now create your timetable based on the courses you are enrolled to, by study program or individual. The software can export to iCal, CSV and PDF and can be found in Blackboard.

## RESEARCH INFORMATION FOR (BACHELOR) STUDENTS

Most Bachelor students have little idea of what goes on in the EWI tower. That's why the ETV, in cooperation with EWI Marketing, is organising an event in May where every research group can talk about the exciting research they are currently working on. Students will hear more about this event as details are confirmed.

# De Facultaire Studentenraad

Wij als facultaire studentenraad, of kort FSR, zijn alweer een tijdje bezig en houden de faculteit goed in de gaten. We hebben in het begin van het collegejaar een 10-puntenplan gemaakt met de 10-punten waar wij dit jaar extra aandacht aan geven. Dit doen wij vooral in onze maandelijkse overlegvergadering met de decaan, maar ook in verschillende werkgroepen in de faculteit, waar onze mening gevraagd is. Een paar van deze punten hebben wij hier even kort toegelicht.

## INVOERING VAN DE HARDE KNIP EN HET BINDEND STUDIE ADVIES.

Eerstejaars krijgen voor het eerst te maken met het bindend studie advies, dat betekent dat ze tijdens hun eerste jaar minimaal 30 ECTS moeten halen en anders helaas niet verder mogen met hun studie. Verder krijgt iedereen uit 2006 en later na dit jaar te maken met de harde knip: eerst alle punten uit je bachelor halen voor je verder mag met je master. Zowel rondom het BSA als de harde knip zijn harde afspraken gemaakt door de studentenraad en wij zullen er op toezien dat deze binnen onze faculteit nageleefd worden.

## UITSTRALING VAN DE FACULTEIT

We zijn dit jaar bezig de uitstraling van onze faculteit te verbeteren. Zowel het hoofdgebouw als gebouw 35 stralen niet uit dat het EWI gebouwen zijn, terwijl dat wel zou moeten. Heb jij werkbare ideeën over de invulling van dit idee, laat dat dan weten!

## DIPLOMAUITREIKINGEN

De ceremonie zoals deze op dit moment een aantal keer per jaar plaatsvindt wordt door velen als saai ervaren. We zoeken naar een oplossing om de uitreikingen leuker te maken terwijl de studenten die hun diploma ophalen toch de verdiende aandacht krijgen. Ook ideeën hierover horen we graag van jullie.

Deze punten krijgen bijzondere aandacht van ons, maar ook alle andere problemen pakken wij natuurlijk aan. Dus heb jij een idee over een van de bovengenoemde punten of kom je zelf andere problemen tegen? Laat dat dan weten via [fsr@ewi.tudelft.nl](mailto:fsr@ewi.tudelft.nl) of spreek een van ons aan op de faculteit. Er is altijd wel iemand te vinden bij de ETV of CH, we zijn te herkennen aan de foto's op de posters die door de hele faculteit hangen. Vergeet ook niet je stem te laten horen bij de volgende verkiezingen van de FSR op 26 en 27 mei!



# Activities of the Electrotechnische Vereeniging



## Excursie CeBIT

Auteur: Patrick Fuchs

Daar stond ik dan 's ochtends (4 uur!) met mijn slaapogen de rest van de groep te zoeken. Toen de bus eindelijk kwam kon ik mijn ogen niet geloven (misschien ook omdat ik m'n contactlenzen niet in had). Dit was de meest luxe bus die ik ooit had gezien. Misschien waren het de zacht leren stoelen, of de vroege vertrektijd, en misschien een combinatie van beiden, maar ik lag wel heel snel te slapen achterin de bus.

Enkele uren later (weer wat opgefrist na een redelijke nachtrust) kwamen we aan op het "messegelaende" waar CeBIT plaatsvindt. Even later stonden we met z'n allen in de eerste zaal. Als eerste natuurlijk langs bij Alcatel-Lucent, die onze kaartjes voor de entree van de CeBIT beurs betaald hadden. Daarna viel de groep redelijk snel uit elkaar en ging iedereen naar de stands of hallen waar ze het meest interesse in hadden. Omdat het beursterrein zo groot was (te vergelijken met het centrale deel van de TU Delft-campus in grootte), had ik sommige mensen de hele dag niet gezien. Aangezien dit de eerste keer was dat ik überhaupt op een ICT-beurs was (afgezien van de Games Convention



Zelfs binnen de grote mensenmassa waren de ETV'ers vanouds goed te onderscheiden.

Leipzig, waar het zwaartepunt toch ergens anders ligt) was ik maar wat gaan lopen, op zoek naar leuke gadgets en goodies.

Dan waren er ook nog de 3D-schermen en -technieken die allemaal naast elkaar geshowd werden. Dit trok natuurlijk de aandacht van veel mensen, maar weerhield ons er echter niet van ook zelf deze briljetjes en beeldschermen te gebruiken en te bekijken. Erover horen is een ding, maar zelf de verschillen vooral waarnemen geeft natuurlijk een heel ander (3D-) beeld. Nadat uwe reporter zelf geïnterviewd was door een Russische tv-zender (over een 3D-bril die ik aan het "testen" was, vond ik het welletjes en gingen we door naar de rest van de hallen.

Jammer genoeg ging de terugreis niet helemaal zonder problemen. We waren namelijk iemand kwijtgeraakt op de CeBIT (waarschijnlijk onderweg naar Hannover voor het avondeten, voor de details moet je maar het Bestuur vragen) waardoor we meer dan een uur vertraging opliepen. Achteraf was iedereen gelukkig naar Delft gekomen en was het een zeer geslaagde excursie. 



De nieuwste gadgets van Asus.

## Excursie Shell

Auteur: Felix Fikke

Op het moment dat voor de meeste studenten het eerste college begon, verzamelde op 16 maart een groep enthousiaste ETV'ers zich op het station van Delft. De reis leidde naar Moerdijk, alwaar we, samen met een delegatie uit Eindhoven, een bezoek brachten aan Shell. De dag was georganiseerd en werd begeleid door Alexander Bosman, een jonge elektro'er die sinds 4 jaar voor Shell werkt. Zoals te verwachten van iemand met deze achtergrond was de dag perfect georganiseerd.

We begonnen met een kleine rondvraag om vast te stellen wat men over het werken bij Shell zou willen weten. Daarna vertelde Alexander over de diversiteit aan carrièremogelijkheden die een multinational als Shell bood. Gevolgd door een presentatie van Joke Driessen met een algemeen praatje over Shell Moerdijk. Deze fabriek is een van de grootste kraakfaciliteiten in Europa. Hier wordt per jaar zo'n 4,5 miljoen ton ruwe aardolie verwerkt tot Nafta, aardgas en andere producten.

Na de presentatie van Joke was het woord aan Wim de Wilt, de 'global manager Electrical Engineering' voor Shell. Hij vertelde boeiend over zijn langdurige carrière bij Shell en beantwoorde een hoop van de in het begin gestelde vragen. Hierna was er gelegenheid om tijdens een kleine lunch met één van de diverse werknemers gesprekjes te voeren en informatie op te doen.

## Lunch lecture Technolution

Author: Lucas van Dijk

On the 9th of March, Dr.ir. Paul van Haren visited our faculty to tell something about Technolution. It was definitely a good and informative lecture, which showed a bit about their design-process for a system they're developing for Philips. He started off telling in what fields Technolution is active. Examples are traffic engineering (NS, ProRail, Rijkswaterstaat), High-Tech (Philips, ASML, OCE and Agfa), and some other fields like telecom and power engineering (KPN, Motorola, Eneco). It's nice to know that Technolution provides solutions to certain problems with existing technology, they don't do any research.

In Holland, there's only one office, and it's located in Gouda. If I may believe Dr.ir. Paul van Haren, there's a nice atmosphere at their company, discussing a lot of new technologies colleagues have discovered. People who finished an electrical engineering, computer science, mathematics or physics study are always required at Technolution as these kinds of people often have a lot of knowledge in one or more of the following fields: electronics, embedded systems, programmeable logic or information systems. In their experience, people from electri-

cal engineering can be used in all four fields, but who expected anything else?

Na de lunch werden we voorzien van beschermende kleding, waarna we een rondleiding door de fabriek kregen. Ons groepje werd begeleid door een oud elektro'er uit Delft. Hij leidde ons langs de kraakovens, transformatoren en andere grote machines. Erg interessant was natuurlijk de controlekamer waar de stroomvoorziening geregeld wordt.

Als afsluiting kregen we nog een aantal zeer waardevolle tips over het solliciteren en stage lopen bij Shell, waarna we vermoeid doch voldaan terugkeerden naar Delft. 



De deelnemers van de Shell-excursie.

After this part, that was mainly about Technolution, he continued describing the design process of a machine which can sort of look inside your body without making any cut. The screen where the inside of the body will be displayed, is huge. Besides only the body view it contains six 'subscreens' which all display data like patient information, machine position, and all you can think of. The resolution of this screen was around 4000x3000 if I'm right, so a good graphicscard is required. It also allows to add external devices to the screen through a DVI connector. They designed their own DVI grabber which can be put in a PCI-E 2.0 slot, and it actually does a lot more than only grabbing the DVI signal: it also compresses and crops the view a bit, because there wouldn't be enough bandwidth available on a PCI-E 2.0 slot to grab 4 external devices at the same time.

There was more on the lecture, but I hope this has given you a good idea about the lecture. They definitely got my interest, because it sounds like a great company which works on a lot of different projects, in all sorts of fields. 

# eeStec

## Eestec LC Delft

Author: Jean-paul Schouwstra

The ETV is a member of the international organization EESTEC, where it is known as EESTEC LC (Local Committee) Delft. The main objective of EESTEC is to improve contacts between electrical engineering students from all over Europe. This is achieved by organizing exchanges, an annual conference, workshops and other great activities. The principle of EESTEC is simple: if you arrange your own trip to your destination location, your accommodation, food and program will be arranged for you. All of the 40 LC's organize an exchange at least once every two year. Activities that participating students can expect are cultural activities, workshops, lectures and most importantly multicultural integration between the students from all the different countries. Do you like this principle and want to stay up to date once a month on upcoming activities and exchanges? Contact [Eestec-news@etv.tudelft.nl](mailto:Eestec-news@etv.tudelft.nl) and subscribe for the Eestec-newsletter!

For this year an enthusiast committee of the ETV started preparing an exchange to Delft. The theme of this exchange is "Size Does Matter". To prove this we have a very large committee, especially compared to other years. This committee will ensure that the week of June the 7th will be an incredible, unforgettable week for the international guests as well as for the Delft students participating.

Wouldn't you like to be brought in contact with a nice foreign electrical engineering student? Well this is your chance. For our exchange to Delft we are still looking for some hosts to provide sleeping places for international students for one week. So if YOU still have some free square meters, please let us know by e-mailing [EESTEC@etv.tudelft.nl](mailto:EESTEC@etv.tudelft.nl)! In return you'll be able to go to some GREAT parties and get the chance to "keer" an exchange student. 🍷



An impression of the last EESTEC-exchange in Delft.

# C2000

Life saving communication?



Author: Stephan Groot

“We need immediate assistance at the Mekelweg 4 in Delft. Over”. “Unit Echo Tango Victor is on route. Over and out”. Seems like a random example of a possible communication message between a mobile unit and the radio control room of one of the emergency services. It holds in general that communication is of vital importance in the operation of emergency services. Therefore it is easily understood that the communication network of the emergency services in the Netherlands, C2000, recently received a lot of attention due to some possible failures of the system.

Since July 1, 2004 C2000 replaced the analog communication networks of Dutch emergency services. Nowadays the police forces, fire departments, ambulances and the Koninklijke Marechaussee (a force providing military police and civil police duties) all use the C2000 system for their communication. Recently, this system caused quite some unrest in the Netherlands, due to some possible failures of the system during some major events. In this article the concerns that are associated with C2000, will be pointed out.

Before we look at the issues that arose with C2000, we first address the reasons for the transfer to C2000. After that a brief technical analysis of the C2000 system will be given. Finally, the problems that arose in using C2000 will be pointed out.

## From analog to digital

In the mid nineties there were several developments, which caused an understanding among the Dutch emergency services that it was necessary to replace the old

analog communications networks. Besides the general tendency towards the digital era, one of the main developments was the insight that the analog system was not providing enough capacity and lacked in security. Besides that, the analog system did not provide the possibility for the different emergency services, like the police, fire squad and ambulances, to communicate with each other. Both the evaluation from the fire at Volendam during the turn of the year 2000 to 2001 and the evaluation of the fireworks explosion

in Enschede, confirmed these issues some years later.

In September 2004 the C2000 was introduced. It took three years before the last police squad, the one of the region Amsterdam-Amstelland, shut their analog network down and switched to C2000. This completed the nationwide migration towards the digital C2000. C2000 belongs to the class of Private Mobile Radio (PMR) systems, which have different requirements than the public communication networks. The specific demands of users of PMR systems will be addressed later. These demands cannot be satisfied by conventional system like GSM, GSM-R and DECT. Therefore a standard, especially suitable for PMR systems, like C2000, is developed.

## TETRA

The C2000 communication network makes use of the standard TETRA, which is an abbreviation for TERrestrial Trunked RAdio. Trunking is a word borrowed from the telephone system to describe a system, in which a large number of users share a much smaller number of communication paths. Traditionally, this was related to a wire (the trunk) that was assigned to a telephone user upon making a call. In the case of terrestrial radio the scarce resource is bandwidth. If we relate this for example to the police in a certain region, where there are at a given time quite a number of police officers on duty, who all need to stay in contact with a dispatcher. If each officer would use an exclusive channel, the available frequency band would soon run out of possible channels. Moreover, this is not a very efficient way to assign radio channels, since each channel would be idle most of the time.

In a trunked radio system the total numbers of users are divided into groups. Imagine waiting with a group of friends for a table at a crowded restaurant. You go up

to the hostess and give her your name, and she puts it on a list with a bunch of other names. If all the tables already have people at them, you wait. When a table is ready the hostess announces your name over the speaker and you and your friends follow her to the table she selected for you (probably the first one that became available). This principle is also applicable to the kind of trunking used in TETRA. When a user of one group wants to talk to a user of another group, he has to request a channel assignment from a controller first. The controller will check if there is a channel free. If all the channels are occupied, the controller makes you wait until a channel is free, and then publicly announces your talk group and the assigned channel. User A and the intended receiving users then switch to that channel and can communicate with each other.

Trunking can be applied to both a part of the conversation or to the entire conversation. The first is implemented in TETRA. In this case a conversation that takes place over several transmissions may actually occur on several different radio channels because the controller may assign a new channel every time someone presses their push-to-talk button. This is the most efficient way to share radio channels, since other people can use the channel during pauses in the conversation, but it is also what makes it more difficult for a normal scanner to listen in.

At this point, one can wonder why use a complete different standard instead of proven technology like GSM. The reason for this is the specific requirements that communication networks for emergency services demand. The traditional techniques, like GSM, have certain issues, discussed here, which are solved in C2000.

- GSM limits the amount of subscribers in a group to 1024 and the amount of dispatchers to 5. In TETRA no restric-

tions on group size are defined, but a group can deal with at most 30 dispatchers. Especially the relative small number of possible dispatchers in GSM is a limitation, since one of the objectives of the network is to enable different emergency services to communicate with each other. This requires many dispatchers. A very effective way of informing members of a group in case of an emergency is trough sending a short data message to each member of the group. This function is defined in TETRA, but is not available in GSM. Of course it is possible to send a SMS in GSM to each member of the group individually. However, this is significantly slower than the service TETRA provides. Besides that, since SMS data files run over the signaling channel of GSM, this will put a significant additional load on the signaling channel, when used extensively.

- Another rather important difference origins in the way how both handle call priorities. Call priorities are specified for both TETRA and GSM. However, TETRA is more flexible in this case, because it can provide different priorities to a user or group. Furthermore, in TETRA more priority classes are specified. Another rather important feature of TETRA that is not incorporated in GSM is the speech item priority. In for example emergency situations it can be important that a group leader can get a speech item and force the other subscribers in the group to listen. This feature can be important to achieve organized communications, which can be critical in an emergency situation.
- When designing a communication network for the emergency service the call set-up time is of huge importance. In C2000 it is required that a call can be set-up within 0.5 seconds. With some efforts the call set-up time in GSM can only be reduced to one second.

- The security of the network is of extreme importance for the intended users of C2000. The security should ensure that someone not belonging to a certain group is unable to listen to the communication, but also is unable to disturb the communication. In TETRA three types of security measures are implemented. First, authentication ensures that only users with a valid key can use the network. Moreover, the call information, the control information and the identity of the users is encrypted, by a so-called Air Interface Encryption (AIE) protocol. This ensures that a user can be tracked by following the signaling messages on the control channel. Last, encryption between the endpoints of communication is provided. End-to-end encryption (e2ee) prevents eavesdropping by encrypting the information on the traffic channel. The difference with AIE is that the information on the control channel isn't encrypted.

## Issues

In 2009 there were several incidents, which caused some distrust in the C2000 system. In February a passenger flight of Turkish Airlines crashed near Schiphol Airport. During the rescue the system had signs of overloading. For example many people couldn't get a proper connection using their radio. Afterwards, the Inspection for Public Order and Safety concluded that the available 11 groups were too little for the vast number of emergency services on site. Another, and maybe one of the most well-known, example of the disfunctioning of C2000 is during the riots on the beach of Hoek van Holland. When the situation escalated, again, the system showed signs of overloading. The police men on site couldn't communicate with each other for some time.

As a result of these incident, the Department of Interior Affairs has investigated

the operation of C2000. One of the outcomes of this investigation is that there are some locations in the Netherlands, where the coverage of C2000 is not sufficient. At these locations the link tends to switch between two different base stations, hence drastically deteriorating the connection. These locations are collected in a so-called DIPP list (Dekkings Issue Prioritering Procedure, in short this means a collection of the important locations, where coverage problems arise). This DIPP list also includes Pernis, where the Dutch petrochemical industry is concentrated, Borssele, the location of a nuclear power plant and Vught, the location of an extra secure prison. Recently was announced the coverage of 60 high-risk locations like these will be optimized within two years.

Although some of the technical shortcomings of C2000 are recognized, the influence of the user on the proper functioning of C2000 also has to be taken into account. For example when evaluating the problems that arose during the plane crash in February, it was concluded emergency people were using their radio for non-essential communication too. If the radio was only used for the important messages, the overloading of the network could have been prevented. The failures of the system, during the riots at Hoek van Holland, but also during the attack on Queen's Day 2009 were ascribed to the fact that there were too many users in the same group. The director of the region Rotterdam-Rijnmond, Don Berghuis, who was appointed for the research, states that many emergency service people all use the same group. Therefore the system seems overloaded. In fact this isn't the case, but because there are many users in one group, individual users need to wait longer before they can speak. When in critical situations people tend to speak at the same time, this gives problems. Berghuis also added that this isn't a specific telecommunications problem.

If ten people are talking to each other in person, communication also won't work if they talk at the same time. To solve this problem, the users of C2000 are trained again to work properly with the system.

## Conclusion

More than a decade ago the Dutch emergency services switched from an analog communication network to a digital one: C2000. Theoretically, this new communication network provides the emergency services with state-of-the-art communication, providing in all their specific demands. However, when using C2000 some issues arose. Especially during major incidents, the system showed signs of overloading. Investigations showed that there exist both technical as user related reasons for these issues. To overcome the technical problem of too little base stations at critical locations, the coming years these base stations will be installed. The users of C2000 are once again trained, in order for them to work properly with the system. Maybe, these two actions will finally enable the emergency services to use their life saving communication system! 📶

## References:

- [1] Terrestrial Trunked Radio – TETRA, P. Stavroulakis, Springer, 2007.
- [2] Eindrapportage expertgroep C2000 – Ministerie van Binnenlandse Zaken en Koninkrijksrelaties, definitieve versie, 22 december 2009.



**HIER INVOEGEN:  
PAGINA 15 SMIT.PDF**

# Controlling the brain

How electrical stimulation can be used as an effective treatment for many brain disorders.

Author: Marijn van Dongen

Our brain is the center of our nervous system. Literally everything we do, from eating an apple to solving a Schrödinger equation, is controlled by it. Usually we don't give much thought to the fact our brain is so utterly important, but imagine something starts to go drastically wrong inside the brain. Not being able to solve a Schrödinger equation might not be a big problem for the majority of people, but eating an apple is.

The list of brain diseases is very long: Alzheimer's disease, Parkinson's disease, Tinnitus and mental disorders (e.g. clinical depression or schizophrenia) are just a few of the well known examples. All these diseases have major impact on the quality of life of the patients. Existing treatments have only limited effectiveness.

During my Master thesis I have looked into the design of a neural stimulator: a device which is able to directly influence the functionality of the brain using electrical stimulation. It turned

out this leads to a very exciting research field with many challenges which need to be solved; both in the medical as well as in the electrical domain.

In this article an introduction will be given in the field of neural stimulation. The focus will be on how the brain works from an electrical point of view and how it is possible to influence this functionality using stimulation. Also an overview is given for the most important innovative features our design is providing compared to existing stimulators.

## Why is brain stimulation effective?

Throughout history medicine has been going through an extensive development. Prehistoric medicine consisted of a combination of very basic drugs (extracted from plants and herbs) and treatments consisting of ceremonies carried out by shamans using supernatural powers and objects (charms, spells, amulets, etc). During the course of history more and more knowledge was gained about the use of drugs for treating diseases. From the 19th century on medicine has gone through a revolution thanks to advances in for exam-

ple chemistry and today drugs form an utterly important ingredient of medical treatments.

However it is more and more realized that drugs alone cannot cure all diseases efficiently enough. Most drugs suffer from unwanted side effects and the spatial selectivity of drugs is usually low: it will have effects on the whole body, while usually a disease is limited to only certain parts. Another form of treatment consists of electromagnetic stimulation of the body. Cells use electromagnetic signals to operate. These signals can be af-

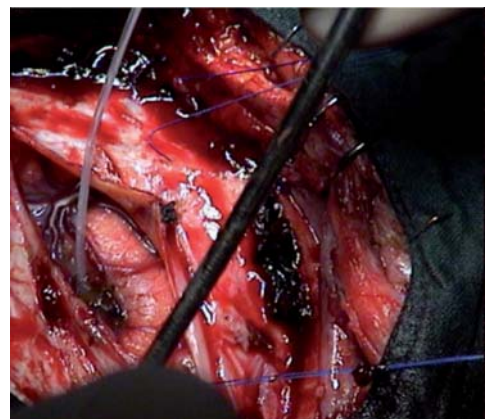
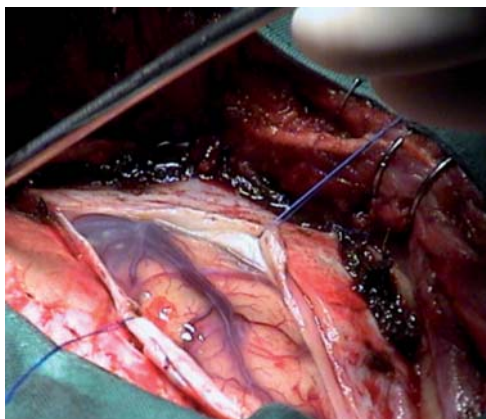

Figure 1: Photo's of the surgical procedure of implanting the electrodes for neural stimulation in the brain. In the right picture the electrode lead is inserted in the brain (pictures courtesy of dr. D. de Ridder)



ected by artificially generated electromagnetic signals in order to establish a desired effect.

Probably the most well known form of stimulation is the pacemaker: a stimulator for the heart muscle. This particular technique has gone through an extensive development as well. As early as 1820 Richard Reece described in his 'Medical Guide' a method for stimulating the heart. A metal rod was inserted in

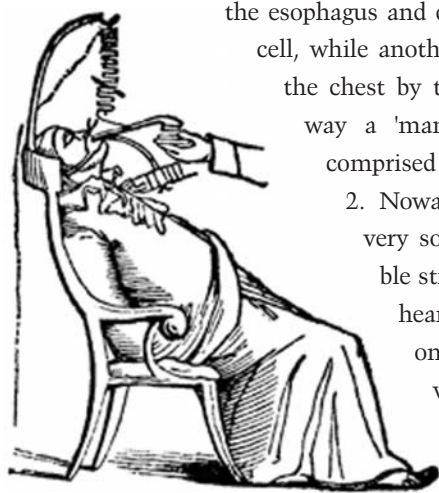

Figure 2: Electrical stimulation anno 1820 according to Richard Reece. A manually controlled non implantable device. State of the art neural stimulators are surprisingly similar to this ancient medical device.

the esophagus and connected to a voltaic cell, while another rod was pushed to the chest by the physician. In this way a 'manual' pacemaker was comprised as depicted in Figure 2. Nowadays pacemakers are very sophisticated implantable stimulators: they record heart activity and based on this activity the device can decide when and how the heart needs to be stimulated.

The brain essentially works in a similar manner as the heart muscle: neural cells communicate by 'activating' each other using electrical impulses.

This means that the activity of the brain can be affected by means of electrical stimulation as well. As shown in the introduction, many diseases find their origin in abnormal brain functionality. It is therefore in principle possible to eliminate this unwanted activity by using brain stimulation. This can be done by implanting electrodes connected to a stimulator, which can deliver stimulation pulses to the tissue.

In this way the functionality of the brain is directly influenced. This results in a much more selective treatment. Side effects are expected to be much smaller, thereby increasing the effectiveness.

The development of neural stimulators is still in a relatively early stage: in some way current stimulators are comparable to the first pacemaker from 1820. Most stimulators have limited implantability as depicted in Figure 3. Furthermore they do not incorporate any feedback: they simply stimulate the neural tissue using a fixed stimulation pattern, without recording the activity in order to adjust the stimulation if required.

## How does neural stimulation work?

Before we can start with the design of a neural stimulator, first a closer look is taken at the physical principles underlying electrical stimulation. It is required to know what exactly happens in the tissue when electrical energy is transferred to an electrode implanted in the brain.

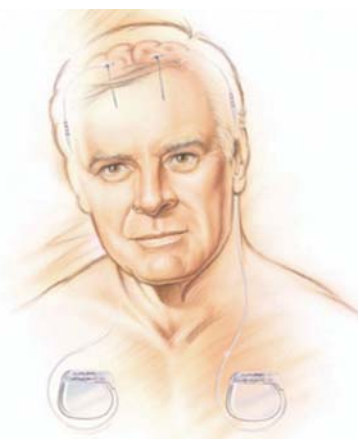

Figure 3: Existing stimulators have limited implantability. The stimulator can only be implanted in the chest, while subcutaneous wires lead to the electrodes in the brain (Image courtesy of Medtronic inc.)

The brain consists of tens of billions neural cells called neurons. A neuron has a cell body (soma) with a nucleus, as depicted in Figure 4. The inputs of the cell are called dendrites and its output is called an axon. Input voltage pulses coming from the dendrites (sometimes thousands of dendrites are connected to a single neuron) are processed in the nucleus and this can result in an output pulse in the axon. These pulses form the fundamental mechanism for all actions in the central nervous system.

The voltage pulses are transferred over the cell membrane, which encloses the neurons and axons. Within this membrane there are ion channels through which different types of ions (mainly potassium, sodium and chloride) can flow. Due to a concentration gradient of the ions between the inside and outside of the membrane, there is a continuous ion flow through this membrane.

The flow of ions is determined by the conductance of the channels, which turns out to be dependent on the membrane voltage. This will eventually lead to a dynamic equilibrium in which ions will flow with a constant rate, yielding a resting potential of the membrane.

Changing the membrane voltage, will change the ion flow accordingly. When the membrane voltage is raised above a particular threshold, the membrane is 'activated' and a process is triggered, which will result in a voltage pulse over the membrane. This pulse, often referred to as an action potential, will propagate over the axon towards other cells.

When an electrode is now placed in the tissue, it is possible to change the outer membrane potential by applying a particular voltage to this electrode. In this way it is possible to »

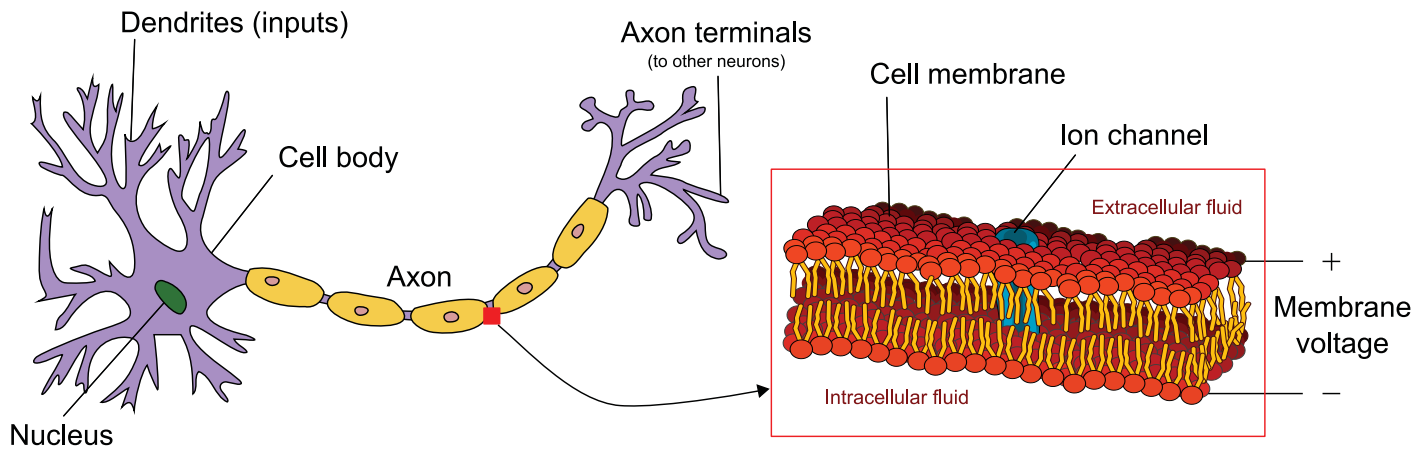

Figure 4: Structure of a typical neuron and a detail of a cell membrane (Image courtesy of Mariana Ruiz and Quasar Jarosz, modified under the Creative Commons BY-SA license.)

change the membrane voltage and therefore action potentials can be artificially generated or blocked. In this way the functionality of the brain can be directly influenced.

Therefore neural stimulation is from an electrical point of view nothing more than elevating the tissue potential (the outer membrane potential) up to a particular threshold. Electrical modeling of the electrode-tissue interface shows a capacitive nature. This means that elevating the tissue potential above a particular threshold corresponds to injecting a particular amount of charge in the tissue. This observation has been a critical starting point in the project.

### Design of the stimulator

The fact that charge is the fundamental electrical quantity for stimulation can be used to design an effective stimulator. However another important design aspect is safety. When applied in the correct way, stimulation can lead to beneficial results in the brain. However, stimulation can also lead to damage to the tissue when certain requirements of the stimulation waveform are not met.

One of the basic safety constraints is that no net charge can be injected into the tissue. Charge at the electrode tissue interface will lead to electrolysis, which is harmful to the tissue. This means that after a stimulation pulse some mechanism must make sure that the injected charge is removed from the tissue again. One fast way to do this is by applying a second, negative pulse with the same charge contents.

Taking these aspects in mind, one of the first choices for the design of a stimulator is the electrical quantity which is used to inject the electrical energy into the tissue. Most of the existing stimulators use constant value current sources to stimulate the tissue, as illustrated in Figure 5a. In this way the amount of charge injected can be quite easily controlled: by enabling a

constant current for a particular amount of time, the charge is defined as  $Q=It$ . There are however a few important drawbacks related to current sources:

- High power consumption

For charge cancellation, the value of the current source must be equal during the stimulation phase as well as the charge cancellation phase. To create accurately matched current sources, a lot of power is required. This will increase the size of the battery. Current stimulators have limited implantability, because of the size constraints which are determined by the battery. Increasing the power efficiency is therefore very important.

- Waveform flexibility

One major drawback of the existing stimulators is the limited adjustability of the waveform. To be able to control the charge easily, usually only square shaped pulses can be injected. Neural tissue shows an amazing adaptability to stimulation. This means that due to the fixed stimulation pattern the tissue will gradually habituate to the stimulation pattern, which means the symptoms of the disease return.

It is expected that habituation can be reduced when it is possible to generate varying stimulation waveforms. Furthermore a wide waveform choice can result in more effective stimulation. Examples include sinusoidal or triangular shapes, asymmetric stimulation and a wide variety of burst stimulation. Using current sources it is hard to realize this: the charge is not controlled as easy anymore compared to the constant current approach. Based on the two observations above and because current is not a fundamental quantity, it was decided to look into alternative electrical quantities to steer the tissue. It was shown that a voltage source (see Figure 5b) yields a much better approach: it is much more power efficient and it is easy to make a variable voltage source for waveform flexibility.

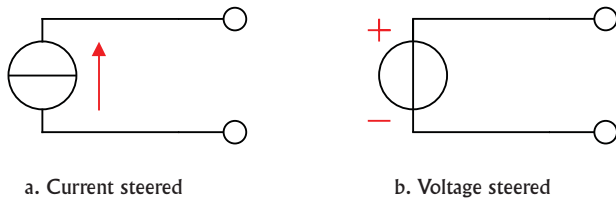

Figure 5: Illustration of two possible fundamental stimulation architectures

The drawback of a voltage source approach is that the charge is not easily controlled anymore, since the current is determined by the tissue impedance, which is very time variant. Therefore it was decided to include a current feedback loop to keep track of the charge injected. In this way it is possible to use any waveform, while still ensuring charge cancellation.

A new type of system architecture was proposed using indirect current feedback. This also implied the use of an additional voltage feedback loop to control the tissue voltage. This double feedback architecture has been implemented in Amis 0.35 $\mu$ m high voltage technology (stimulation voltages used are up to 20V). This principle is depicted in Figure 6.

The implementation details of the system are beyond the scope of this article, but probably the most challenging part of the design was the current feedback loop in which an integrator needed to determine the charge injected based on the stimulation current. This integrator was required to handle a dynamic range of several decades of magnitude.

## Results

Simulation results on circuit level show the feasibility of the system. An example of a stimulation waveform generated by the circuit (1kHz, 2V amplitude and 7V offset) was injected

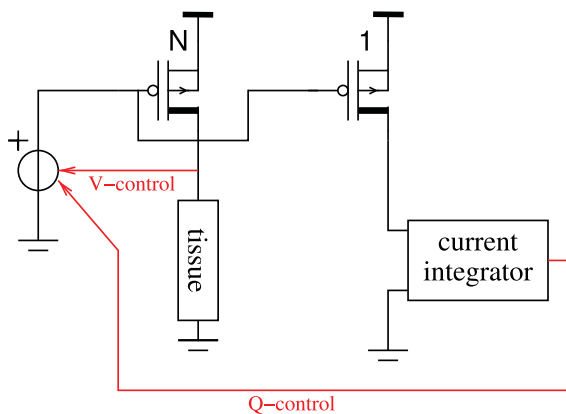

Figure 6: The principle of indirect current feedback with direct voltage feedback, which is used as the fundamental system architecture.

into the tissue (modeled as a parallel combination of a resistor of 10k $\Omega$  and a capacitor of 75nF). The charge threshold was set to 171nC. The transient simulation result of the tissue voltage is depicted in Figure 7. As can be seen, the tissue is first charged to about -2.3V during the first (negative) voltage pulse. Subsequently a positive pulse is injected to remove the charge at the tissue. As can be seen the resulting tissue voltage is very close to zero, indicating the charge metering technique is working properly.

One of the design goals was to have a very low power consumption to increase the implantability of the device. Active power consumption is very dependent on the waveform used. Therefore it is hard to quantify the active power consumption or efficiency of the design.

The quiescent power consumption is however as low as 15 $\mu$ W. Most of this power is burnt in the voltage feedback network to bias the gain stage here. Furthermore the switches require some bias to generate a floating voltage source controlling the switches. The quiescent power consumption is to the best of our knowledge among the lowest values for quiescent power consumption reported until now.

An important safety performance parameter is charge mismatch. In the waveform from Figure 7 the remaining charge was 1.5nC, corresponding to about 1%. About 50% of this mismatch is due to discharge of the tissue in the inter-pulse delay because of the finite off resistance of the switches in the switch array. This mismatch can therefore easily be removed when the inter-pulse delay is chosen to be shorter. Further another 40% of the charge imbalance is due to inaccuracies in the implementation of the integrator. When these inaccuracies »

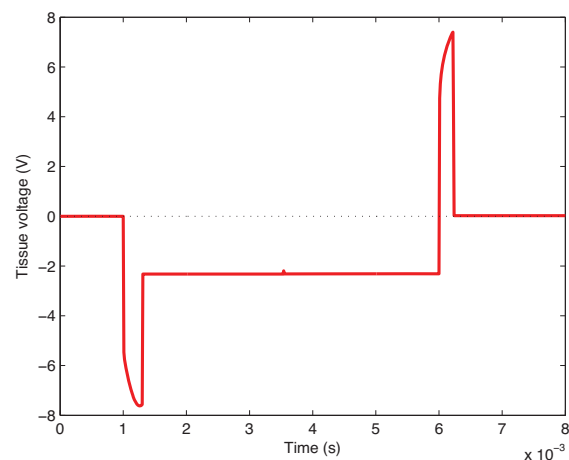

Figure 7: Tissue voltage during excitation with a sinusoidal waveform. The final tissue voltage is close to 0V, illustrating the feasibility of the system.

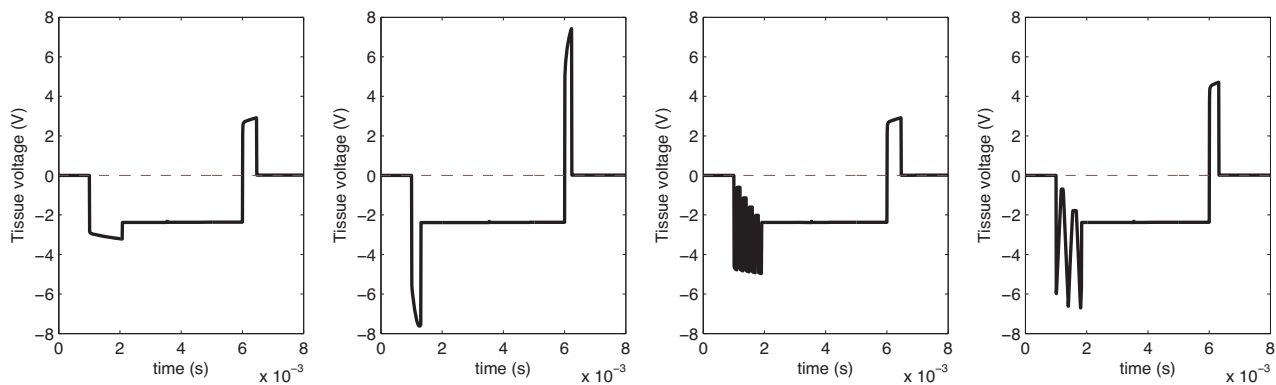

Figure 8: Illustration of the endless waveform shape possibilities. The tissue voltage is shown for two different tonic and burst stimulation waveforms, while charge cancellation is preserved.

are improved, the charge mismatch will become 0.1%. Any remaining charge can be discharged from the tissue by short circuiting the tissue electrodes using the switch array if needed.

Another safety parameter is the ability to handle the large spread in stimulation and tissue parameters. The system is working for any combination in tissue parameters ranging from  $1\text{k}\Omega < R < 100\text{k}\Omega$  and  $10\text{nF} < C < 100\mu\text{F}$ . Furthermore the system is also working over all process corners and process mismatches, preserving charge cancellation.

Because of the chosen architecture there are endless possibilities for waveform adjustments. In principle any waveform can be used: the charge metering mechanism will keep track of the charge injected in the tissue. It is therefore possible to use tonic stimulation, burst stimulation, asymmetric stimulation, sub-threshold prepulses, excitatory and inhibitory stimulation, etc.

To illustrate this two waveforms for both tonic and burst stimulation are depicted in Figure 8. This figure illustrates the charge cancellation mechanism is working for a wide variety of shapes, since the final voltage is very close to zero.

## Conclusions

It has been shown that electrical stimulation of the brain opens up a huge field of treatments for a wide variety of diseases. Because of the highly selective properties of neural stimulation it can offer more effective treatments in many cases compared to the use of drugs.

The physical principles underlying electrical stimulation of neurons have been investigated in detail. It was shown that from a electrical point of view the stimulation of neural tissue is equivalent to raising the extracellular potential up to a particular threshold value. Because of the capacitive nature of the electrode tissue interface, this is equivalent to injecting a particular amount of charge into the tissue.

Taking this principle in mind, a fundamental new system architecture was designed and implemented on the circuit level. Simulation results confirm the feasibility of the system. Furthermore the system has a very versatile character (endless waveform possibilities), very low power consumption, while safety is still assured.

This design opens the way to more efficient neural stimulation treatment methods. Still, there is much room for improvement. System blocks like the external communication, power management and an automated feedback loop (stimulation based on recording neural activity) still need to be designed. Therefore this project will continue in order to design the remaining system blocks to finally come up with a completely new and revolutionary neural stimulator.

The project is carried out in cooperation with many university hospitals, especially the BRAI2N clinic in the University Hospital of Antwerp (UZA). The multidisciplinary approach of this project is something I have very much enjoyed during the course of the project.

If you have questions related to this article or you are interested in the details of the electronic implementation, you are very welcome to contact us. Within our group we are also always looking for motivated students who are willing to contribute to this challenging project or other projects in the biomedical field. The contact details for me and my supervisor Wouter Serdijn are as follows:

Biomedical electronics group, Elca Research Laboratory,  
Mekelweg 4, 2628CD Delft

Marijn van Dongen  
Room HB 18.030  
marijnvandongen@gmail.com

dr. ir. Wouter Serdijn  
Room HB 18.310  
W.A.Serdijn@tudelft.nl



**HIER INVOEGEN:  
PAGINA 21 TNO.PDF**

# Avionics

## The main contributor to innovation in aviation

The need for a specialization of Electrical Engineers in the area of Avionics was already recognized in 1976 by prof. van Oosterom from the Faculty of Aerospace Engineering at Delft University of Technology (at that time still TH Delft). To address the identified need, in 1979 the Faculty of Electrical Engineering started a special program which aimed to educate interested students with a background in Electrical Engineering in the area of Avionics. At present, it is an interfaculty specialization profile. Although having been restructured several times in the past 30 years, the core philosophy of the program remains the same:

- Use a set of coherent courses from the Faculty of Aerospace Engineering and the Faculty of Electrical Engineering to provide the students with the background needed to successfully perform an M.Sc. research project in the area of Avionics.
- Focus the Avionics research on a number of internationally recognized challenges and

pursue them through international cooperation.

- Maintain a state-of-the-art research infrastructure to provide an inspiring learning and research environment.

The frequent reception of best-student paper awards at the largest international Avionics conference (organized jointly by IEEE and AIAA) and the contribution of many former EWI Avionics students in highly visible international research programs (such as the NASA Aviation Safety Program) prove that this approach is very successful. To provide EWI students that are fascinated by aviation a better idea of how they can obtain the required background for a future career in the field of Avionics, this article starts with a brief overview of today's challenges. Using examples from previous and current international research projects, it is illustrated how M.Sc. and Ph.D. students and researchers from EWI have contributed to defining the future state-of-the-art in Avionics.

Figure 1 (background): Cockpit of EWI simulator.



Avionics refers to Electronic systems used in Aviation, and the word itself is a blend of Aviation and Electronics. Avionics are not only essential for today's commercial and military aircraft to fly, but also enable their integration into the overall traffic management system. For safety critical applications such as navigation, aviation imposes requirements and constraints on the electronics system which are far more stringent than for example in the consumer electronics domain. This has an impact on the design of the Avionics.

Author: Dr.ir. Erik Theunissen

### Innovation in aviation

When comparing a Boeing 747 that was built in 1969 with a Boeing 747 built in 2010, the biggest leap in capabilities can be attributed to Avionics. Engines have become far more efficient through the use of Fully Autonomous Digital Engine Control (FADEC). Safety has increased through the introduction of the Enhanced Ground Proximity Warning System (EGPWS) and the Traffic alert and Collision Avoidance System (TCAS). Through better integration and automation, the number of crew members that is required to operate the aircraft has been reduced to two. The instrument Landing System (ILS) provides the capability to land under zero visibility conditions, and the Flight Management System (FMS) allows fuel optimized path to be flown. Indeed, in the past 40 years, a large part of the innovation in the aviation domain was the result of developments in the area of Avionics.

The reason for this leap is that for Avionics the enablers lie in the electronics domain and hence

many capabilities advance with the speed of Moore's law. Also today, the challenge for Avionics is to benefit from this advantage when addressing the issues aviation is confronted with.

The following four issues are internationally regarded as top priorities:

1. Reduction in the environmental burden caused by aviation
2. Further increase in safety, both in the air and on the airport
3. Further increase in airport availability (independent of the actual weather)
4. Integration of unmanned aircraft into controlled airspace

Environment: There is still ample potential of Avionics to reduce the burden of Aviation on the environment. The theme of the IEEE/AIAA 2010 Digital Avionics Systems Conference (DASC) is 'Greening Aviation'. Whereas today's instrument landing system only



provides guidance for straight-in approaches, future Avionics systems, enabled by more accurate and reliable sensors, will support precision guidance along curved paths. This provides the opportunity to circumvent noise sensitive areas that lie below the current approach paths. Through optimized navigation in the vertical dimension, the current transitions between level and descending path segments during an approach can be minimized or even eliminated, allowing a significant reduction in the required engine thrust and thus reducing emissions. To safely fly these more complex approaches, advanced cockpit displays are required to provide the pilot with the information needed to assess whether the aircraft stays free of any hazards.

**Safety:** During the past thirty years, the major improvements in the safety of commercial aviation were achieved through the extrapolation of sensor-based information. To reduce midair collisions, TCAS interrogates the transponders on board of other aircraft to determine whether there is a collision hazard. Likewise, GPWS uses data from the radar altimeter to determine whether the aircraft inadvertently is getting close to the terrain. In the past ten years, the developments in the area of compact data storage have allowed GPWS to be augmented with a warning system that relies on the use of a worldwide terrain database and GPS-based position information. These databases can also serve to provide the pilot with a synthetic view of the environment, independent of visibility conditions. Before actual operational credit can be taken for this capability, a concept is needed that timely detects hazardous discrepancies between the database and the real world.

**Availability:** Whereas large airports such as Schiphol are equipped with guidance systems that allow properly equipped aircraft to land under zero visibility conditions, many smaller airports do not have such equipment. Reasons comprise cost of the required infrastructure but also location. In a mountainous environment, today's ILS cannot be deployed because of undesired signal reflections. A navigation system that meets or exceeds the accuracy, continuity and integrity requirements of today's (ground-based) ILS without requiring significant infrastructure on the ground is one of the top priorities for Avionics research.

**Unmanned aircraft:** Recent guidance from the U.S. Federal Aviation Administration (FAA) suggests that self separation needs to be a component of an Unmanned Aircraft System (UAS) Sense

and Avoid solution in order for UAS to behave similarly to manned aircraft. Conceptually, UAS self separation is the protective (or conflict avoidance) method that precludes a threat aircraft from ever triggering a time-critical collision avoidance maneuver. To realize such a self-separation capability requires an Avionics system comprising sensors to detect the collision hazards, algorithms to filter out observation noise and compute solutions for those threats that are identified as real ones, and user interface concepts to allow an operator to monitor the situation.

## Avionics research @EWI

Within the EWI Avionics research program, specific challenges related to the aforementioned issues are being addressed. To benefit from similarities between the different challenges, the research is structured along common themes such as integrity, path optimization and human machine interfaces. The expertise at EWI covers hardware, software, algorithms, user-interfaces and system interfaces, allowing the multidisciplinary challenges that are typical for Avionics to be properly addressed. The EWI Avionics research has an excellent reputation on an international level. In 1998 the Faculty of Electrical Engineering (EE) was invited by industry to join them in an effort to compete for research in the context of the NASA Aviation Safety Program. As part of a team lead by Avionics manufacturer Rockwell Collins, synthetic vision system prototypes were developed, integrated and first flight tested in 2000. Based on the results, Avionics researchers from EWI further refined these prototypes and in 2001 the resulting system was success-



Figure 2: Cockpit of NASA 757 with EWI SVS.



fully evaluated in the NASA Boeing 757 during the Eagle-Vail flight tests (figure 2). In August and September 2001 more than 100 continuous descending curved approaches were flown in a terrain challenged environment.

One of the Avionics students that became involved in the research in 1999 during his M.Sc. project stayed on as a part-time researcher and was one of the three engineers that Rockwell Collins allocated to support this NASA flight-test program. For the contribution to the overall NASA Aviation Safety program the Turning Goals Into Reality Award was received.



Figure 3: Interior of NASA GV.

The system test flown in 2001 relied on the use of a digital terrain database to provide the pilot with information about the terrain hazards. The Achilles-heel of any database-oriented system is that errors in the database can cause terrain hazards present in the flight path of the aircraft not to be depicted. To enable timely detection of hazardous discrepancies between the real environment and the synthetic environment, the prototype system was extended with the capability to integrate a real-time sensor images. In 2004, four EWI Avionics researchers participated in the NASA flighttests during which this system was evaluated (figure 3).

As indicated earlier, part of the focus is on unmanned systems. Several Avionics students performed their research in this area on topics such as automatic landing systems, air-space integration and the use of networks to achieve control from geographically separated locations. Prototypes of UAV mission management stations developed in a joint project between EWI and the Royal Netherlands Naval College are used by the Royal Netherlands Air Force to explore new concepts of operation using mission level simulations.

The amount of rewards that has been received indicates that the quality of both the M.Sc. projects and the overall research is internationally recognized. In 2005, M.Sc. student de Vries received the IEEE/AIAA Best Student Paper Award at the DASC for his Avionics research project. The following year, M.Sc. student 't Hart received this award for his M.Sc. project that focused on UAV control. In the past five years, the Avionics research was awarded with a total of fourteen international awards, two of which (in 2007 and 2008) were 'Best of Conference'.

## Avionics education @EWI

The EWI Avionics program prepares interested students with the background required to become an Avionics Engineer. This involves both courses such as ET4138 which focus on the Avionics systems and courses at Aerospace Engineering dealing with aircraft performance (AE4-220ET) and flight dynamics (AE3-302)

The Avionics program is supported through an excellent research infrastructure. Room 20.320 on the 20th floor houses a research UAV operator station with which new concepts for mission management can be evaluated. Room 20.070 houses a research flight deck, equipped with a programmable Electronic Flight Instrument System, a Flight Management System, simulation of all required sensor systems, and a projection system to simulate the view out of the cockpit (figure 1). This flightdeck is used both for research projects and in the avionics education program (ET4244).

Avionics is a fascinating area and quite frequently students that became involved with a particular topic during their M.Sc. project continued to work in this area. Some during a subsequent PhD research project, some as a researcher at EWI or another University such as Ohio, and others at institutes such as NLR, organisations such as LVNL and companies such as ADSE and Rockwell Collins.

If you are a student at EWI and fascinated by aviation, you should certainly consider the opportunity to become an Avionics engineer. EWI provides an excellent Avionics education program that prepares you for a future where you can successfully compete with the best of the best. ●

# Innovatie in Trammetjesland

Een van de meest onderstreepte features van de nieuwe TU campus is de tramlijn die door de TU-wijk zal gaan rijden. Prof. Lou van der Sluis vertelt ons in een interview een paar leuke weetjes over de vernieuwingen op het gebied van bovenleidingloze trams en wat dit te betekenen heeft voor tramlijn 19, die door het Mekelpark zal lopen.

**Auteurs: Ben Allen en Benjamin Gardiner**

De aanleg van tramlijn 19 is al aardig op weg. Merkbaar zelfs, voor iedereen die 18 maart op de TU wijk aanwezig was. Tijdens graafwerkzaamheden is een 10kV kabel geraakt, die dezelfde dag nog vervangen moest worden. Als consequentie hiervan kwam de TU-wijk een avond lang zonder elektriciteit te zitten, waardoor de bezigheden neergelegd moesten worden en alle gebouwen ontruimd werden. Ook gaan er geluiden over de campus dat de faculteit Technische Natuurwetenschappen niet erg blij is met de tram vanwege storende invloeden

die de bovenleiding zou veroorzaken. Op zoek naar de waarheid gingen

bovenstaande auteurs op bezoek bij professor Lou van der Sluis, om te vragen welke van die geruchten waar zijn en wat we kunnen verwachten bij de implementatie van tramlijn 19. In rood de vragen danwel opmerkingen van bovenstaande auteurs, in zwart de reactie van professor van der Sluis.

*Wij hadden gehoord dat u iets meer wist over de draadloze tram die door het Mekelpark komt en daar wilden wij graag iets meer over weten.*

Er komt een tram door het Mekelpark, lijn 19, maar dat heeft een vervelend neveneffect. De bovenleiding van de tram, daar loopt natuurlijk een stroom door, die een magneetveld gaat produceren. Dat magneetveld zou in een aantal gebouwen, en met name TNW (Technische Natuurwetenschappen, red.), zeer gevoelige

metingen kunnen beïnvloeden. Dit is natuurlijk erg vervelend, dus wat we gedaan hebben

is in een klein comité een compensatiesysteem bedenken. Dat compensatiesysteem is bedacht door Prof.dr.ir. P. Kruit en dat is later naar de markt gewerkt door een projectgroep waar ik de voorzitter van was.

Je kunt de bovenleiding zo uitvoeren dat je geen last meer hebt van de magneetvelden op een afstand van 100 meter. In de trammetjeswereld is er echter een ontwikkeling gaande dat trammetjes op batterijen en accu's beginnen te rijden, en tegenwoordig gaat dat ook met een supercapaciteit. Dat is het College van Bestuur ter ore gekomen, en die hebben toen gevraagd: "Kunnen we niet van die bovenleiding af?" Dat scheelt kosten, en de bovenleiding verpest het uitzicht niet.

Dus wordt er ook gekeken naar de mogelijkheid van zo'n accutram. Maar je hebt ook een maatschappij die de tram moet laten rijden – de HTM – en die heeft een plan voor het aanschaffen van nieuw materieel. De oplossing hier moet ook in dat plan passen. Dus of er over het Mekelpark een trammetje zal rijden op accu's of supercapaciteit, dat weet ik niet. Je moet sowieso wel kijken naar innovatie in Trammetjesland.

*Met het oog op de route van lijn 19 door Ypenburg, is het nou het idee dat de tram alleen in het Mekelpark zonder bovenleiding zou rijden, of over het hele traject?*

Nou, de actieradius van zo een tram is erg beperkt, dat is eerder honderden meters dan kilometers, dus in het uiterste geval ben je na een of twee kilometers wel klaar.

In Nice hebben ze zo een tram rijden - als je namelijk een beschermd stadsgezicht hebt is dat een leuk alternatief. Het voor-

**“ER KOMT EEN TRAM DOOR HET MEKELPARK, LIJN 19, MAAR DAT HEEFT EEN VERVELEND NEVENEFFECT.”**

## WAT IS EEN SUPERCAPACITOR?

Supercapacitors hebben een capaciteit die vele malen groter is dan die van een conventionele elektrolytische condensator. De techniek die toegepast wordt stelt men in staat om veel hogere energiedichtheden te halen. Op moment van schrijven is de hoogste energiedichtheid die geproduceerd wordt 30 W·h/kg.



Figuur 1. Een 2.5V 350F supercondensator.

deel van zo een tram op accus is dat als de tram remt, kan je die energie opnemen in de accus en weer optrekken door gebruik te maken van deze energie. Per saldo, van de energiekosten uitgerekend, zou je die tram wel eens terug kunnen verdienen.

*Wij zijn eigenlijk wel nieuwsgierig naar het compensatiesysteem. Hoe hebben jullie dat voor elkaar gekregen?*

Je hebt wel eens gehoord van een magnetische dipool, denk ik. Een magneet is uiteraard een magnetische dipool. Maar als je een door een draadje een stroom stuurt, in een kringetje, dan krijg je een magnetisch veld en dan heb je ook een magnetische dipool. En op een afstandje weet je niet of het een statisch veld is van een draadje of van een magneet. Die magnetische dipool komt dus doordat dat draadje een oppervlak heeft. Dus als je je voorstelt dat de bovenleiding de stroom aanvoert, gelijkstroom, gaat die door de pantograaf, door de motor, en via de rails weer terug naar de voeding. Nu zie je dat daar een enorme lus in zit - dat is de dipool. En de vraag is dus "hoe krijg ik die dipool weg?"

Wat we bedacht hebben is om de dipool weg te halen door de draadjes heel dicht bij elkaar te leggen.

Je knipt de bovenleiding in stukjes. De palen van die bovenleiding staan op 40 meter van elkaar en de bovenleiding knip je door bij elke paal. Als je in gedachten houdt dat de retourstroom via de rails gaat en als je nou de voedende kabel langs de rails legt en je trekt hem bij de paal op en verbindt hem met de bovenleiding, dan heb je dus maar een heel klein lusje gecreëerd en die tram gaat van lusje naar lusje naar lusje. Op die manier heb je die dipool enorm verkleind.

*Ik vraag me af hoe die supercondensatoren danwel accus van energie voorzien worden, ik neem aan dat ze die uit de bovenleiding halen?*

Ja ja, dat is zo. Hetzelfde idee wordt gebruikt voor de Rijngouwelijn, dus Gouda - Leiden - Katwijk, daar willen ze ook bepaalde stukken geen bovenleiding hebben, daar ben ik ook een beetje bij betrokken. Je zou dus kunnen denken dat je bij

#### ACCU'S

Een andere mogelijkheid dan de supercondensator is de welbekende Li-ion accu. Dezelfde technologie die in je laptop zit kan, indien groot genoeg uitgevoerd, trams en auto's laten rijden. Bekend voorbeeld: De Toyota Prius.

elke halte, zodra de tram stilstaat, hem even oplaadt, dan heb je helemaal geen bovenleiding meer nodig. In Nice is het zo, dat hij in stukjes zonder bovenleiding rijdt en op sommige stukken wel. Dat is een mooie oplossing voor het opladen.

*Bij de Rijngouwelijn is het toch zo dat Leiden aardig dwarsligt? Wordt het een traject met alleen bovenleiding of maakt de accutram nog een kans?*

Er is nog niets besloten. De provincie heeft nou een studie bij mij uitbesteed om te kijken of dat haalbaar is of niet. De kogel is dus nog niet door de kerk. 📍



Figuur 2. Een tram in Amsterdam

*Cooking with...*

Rob Remis

# American Pancakes



The following description of an American breakfast is taken from [www.businessdictionary.com](http://www.businessdictionary.com): American breakfast generally includes most or all of the following: two eggs (fried or poached), sliced bacon or sausages, sliced bread or toast with jam/jelly/butter, pancakes with syrup, cornflakes or other cereal, coffee/tea, orange/grapefruit juice.

Right. I think that having such a breakfast every morning is probably not the healthiest thing to do. I have to admit, however, that now and then I do prepare American pancakes for breakfast. Once, during a conference visit in the US, I had pancakes and I was immediately hooked. They tasted really good and since then I occasionally turn the kitchen into a pancake factory.

## Ingredients (for 3 to 4 persons)

- Flour (300 grams)
- Buttermilk (0.5 liter)
- Four teaspoons of baking powder
- Four eggs
- Two or three tablespoons of granulated sugar
- Two tablespoons of melted butter
- One teaspoon of salt



American pancakes (also known as hotcakes, griddlecakes, or flapjacks) are easy and fun to make, especially for a leisurely Sunday breakfast or brunch. Before messing up your kitchen, you might want to set the breakfast table first, and make sure that everything looks nice. Now the real “cooking” can start. First, combine all the dry ingredients (salt, sugar, flour, and baking powder). Then whisk the eggs and the milk and blend in the melted butter. Finally, mix everything until there are no lumps left. Cook your pancakes on a hot griddle (a flat and rimless pan). You can check the temperature by pouring a little bit of water on the surface of the griddle. When the water sizzles, the griddle is ready for action. For each pancake, pour  $\frac{1}{4}$ -cup of batter onto the hot surface of the griddle and turn your pancake over as soon as bubbles start to appear. This is it, basically. There is really nothing to it. To keep your pancakes warm, place them in a mildly hot oven.

Serve your pancakes with butter and syrup and add your own favorite toppings. I like to serve my pancakes with bacon and fresh fruit (bananas or strawberries, for example), but other tasty toppings such as chocolate chips, powdered sugar, jam, or raisins also go very well with pancakes. ➦

*Enjoy!*

**HIER INVOEGEN:  
PAGINA 29 MASTERVOLT.PDF**

# TTEthernet

A Powerful Network Solution for All Purposes

Author: Dr. Markus Plankensteiner, Head of Marketing  
TTTech Computertechnik AG



## From Ethernet to TTEthernet

Over the last years there has been discussion about how to adapt Ethernet for new application domains. Its focus has been on the use of Ethernet for real-time tasks in industrial environments. More than 20 different approaches are now struggling for recognition in industrial automation alone.

Today's Ethernet systems have limits when it comes to combining them with classical Ethernet networks, devices and services. The scalability of these systems is also limited and the network solution is tailored for a specific application area. TTEthernet combines the proven determinism, fault-tolerance and real-time properties of the time-triggered technology with the flexibility, dynamics and legacy of "best effort" of Ethernet and is therefore suited for all types of applications.

Considering networking technologies in general, one can distinguish between closed, statically configured embedded networks and open, dynamic networks allowing free-form communication. Whereas statically configured communication networks enable reliable data transmission in real time, free-form communication networks perform only on a best-effort basis, i.e., there is no guarantee if and when data messages are transmitted. As statically configured systems usually need to comply with strict safety are based on dedicated standards, the number of communication nodes is known and not very flexible. Open standards, like the TCP/IP/Ethernet stack that drives the

Internet, form the basis of free-form communication and the number of nodes in systems is arbitrary. TTEthernet brings together the high flexibility of free-form systems and the reliability and speed of statically configured systems (see Figure 1).

## TTEthernet Design Objectives

TTEthernet enables the seamless communication of all applications by way of Ethernet. Conventional PCs, web and office devices, multimedia systems, real-time systems and safety-critical systems are to use the same network. A single network that is completely compatible with the IEEE Ethernet 802.3 standards is suited for data transmission among different applications with various requirements. A single network solution could thus be used for all applications in airplanes, ranging from the entertainment program, to board supply, electronic navigation and guidance system, and internet access in passenger seats. Critical areas are accordingly made fail-safe or fail-operational. Fault tolerance mechanisms avoid the fault propagation in the system and prevent potential hackers from unauthorized access to resources.

TTEthernet is scalable. Networks that connect uncritical applications shall be able to transmit real-time data in distributed controls and shall be suited for safety-critical applications in the future. Existing applications need not be changed when the network is extended in terms of functionality. Time-critical messages always take precedence over less important messages in TTEthernet. This does not affect conventional applications. The temporal behavior of the time-critical messages is predictable and can be characterized depending on the required quality.

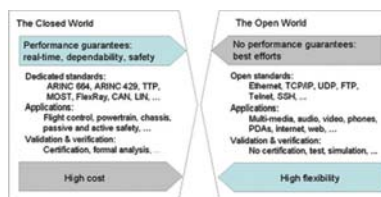

Fig. 1: TTEthernet combines closed-world and open-world systems on the basis of IEEE 802.3 Ethernet standards.

TTEthernet is used for safety-critical fail-operational applications. This means that the system remains fully functional even if a failure occurs. No matter if a node, a switch or a network branch is faulty, the network continues safe communication. This fact accounts for the essential difference between TTEthernet and other Safe Ethernet systems. The latter systems, which are sufficient for industrial applications detect faults in the network and switch the system to a safe state, e.g. stopping the engine. In order to secure the availability of the system even if a failure occurs, TTEthernet provides a variety of network services such as a clock synchronization service, a startup service and clique detection and recovery services. The behavior of TTEthernet is precisely predictable and thus formally verifiable.

## TTEthernet System Properties

TTEthernet has time-triggered services that enable time triggered communication over Ethernet. These time-triggered services establish and maintain a global time, which is realized by the close synchronization of local clocks of the devices. The global time forms the basis for system properties such as temporal partitioning, precise diagnosis, efficient resource utilization, or composability.

**Temporal Partitioning:** The global time can be used as a powerful isolation mechanism when devices become faulty; we say that the global time operates as a “temporal firewall”. In case of failure it is not possible for a faulty application to untimely access the network. Depending on the location of the failure, either the communication controller itself or the switch will block faulty transmission attempts. Failures of the switch can be masked by powerful end-to-end arguments such as CRCs or by high-integrity designs.

**Efficient Resource Utilization:** The global time contributes to efficient resource utilization in several ways. Time-triggered communication allows minimizing the memory buffers in network devices as the time-triggered communication schedule is free of conflicts. Hence, switches do not have to be prepared for bursts of messages that have to be delivered over the same physical link. A minimal time-triggered switch design could even multiplex media access logic such as reception or transmission logic. A second way of effective resource utilization is buffer memory in the nodes, which can be minimized as the sensor values can be acquired according to the global time, immediately before sending the message. Finally, a third way of effective

resource utilization is power management in which energy can be seen, and saved, analogously to memory.

**Precise Diagnosis:** A global time stamping service simplifies the process of reconstruction of a chain of distributed events. On the other hand, the synchronous capturing of sensor values allows building snapshots of the state of the overall systems.

**Composability:** The global time allows the specification of devices not only in the value domain, but also in the temporal domain. This means that already during the design process of devices, the access pattern to the communication network can be defined. The devices can then be developed in parallel activities. Upon integration of the individual devices, it is guaranteed that prior services are stable

and that the individual devices operate as a coordinated whole.

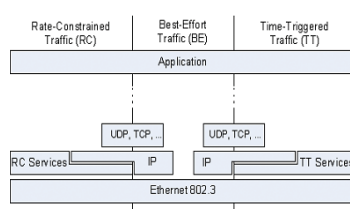

Fig. 2: Relation of TTEthernet to existing communication standards

## Dataflow Options in TTEthernet

TTEthernet specifies services that enable time-triggered communication on top of Ethernet. The time-triggered services can be viewed parallel to the usual

OSI layers: a communication controller that implements these services is able to synchronize with other communication controllers and switches in the system. It can then send messages at points in time derived from this system-wide synchronization. These messages are then called time-triggered messages.

As TTEthernet supports communication among applications with various real-time and safety requirements over a network, three different traffic types are provided: time-triggered (TT) traffic, rate-constrained (RC) traffic, and best-effort (BE) traffic. If required, the corresponding traffic type of a message can be identified based on a message’s Ethernet Destination address. The relation of the TTEthernet traffic types to existing standards is depicted in Figure 2.

Messages from higher layer protocols, like IP or UDP, can be “made” time-triggered without modifications of the messages’ contents itself. The TTEthernet protocol overhead is transmitted in dedicated messages termed protocol control frames, which are used to establish system-wide synchronization. In short, TTEthernet is only concerned

with “when” a data message is sent, not with specific contents within in a message.

TT messages are used for time-triggered applications. All TT messages are sent over the network at predefined times and take precedence over all other traffic types. TT messages are optimally suited for communication in distributed real-time systems. TT messages are typically used for brake-by-wire and steer-by-wire systems that close rapid control loops over the network. TT messages allow designing and testing strictly deterministic distributed systems, where the behavior of all system components can be specified, analyzed and tested with sub-micro second precision.

RC messages are used for applications with less stringent determinism and real-time requirements than strictly time-triggered applications. RC messages guarantee that bandwidth is predefined for each application, and delays and temporal deviations have defined limits. RC messages are used for safety-critical automotive and aerospace applications that depend on highly reliable communication and have moderate temporal quality requirements. Typically, RC messages are also used for multimedia systems.

In contrast to TT messages, RC messages are not sent with respect to a system-wide synchronized time base. Hence, different communication controllers may send RC messages at the same point in time to the same receiver. As a consequence, the RC messages may queue up in the network switches, leading to increased transmission jitter. As the transmission rate of the RC messages is bound a priori and controlled in the network switches, an upper bound on

the transmission jitter can be calculated off-line and message loss is prevented.

BE messages follow a method that is well-known in classical Ethernet networks. There is no guarantee whether and when these messages can be transmitted, what delays occur and if BE messages arrive at the recipient. BE mes-

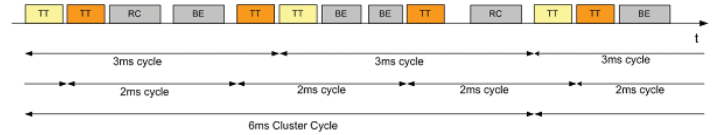

Fig. 3: TTEthernet includes TT, RC and BE messages.

sages use the remaining bandwidth of the network and have less priority than TT and RC messages. Typical user of BE messages are web services. All legacy Ethernet traffic (e.g. internet protocols) without any QoS requirement can be mapped to this service class. TTEthernet implements strong partitioning between non-critical BE traffic and all other service classes (see Figure 3).

### TTEthernet as Transparent Synchronization Protocol

TTEthernet is a transparent synchronization protocol, i.e., it is able to co-exist with other traffic, potentially legacy traffic, on the same physical communication network. For reasons of fault tolerance a multitude of devices can be configured to generate synchronization messages. The devices generating the synchronization messages may be distributed with a high number of intermediate devices in between each other.



Fig. 4: A test setup for TTEthernet



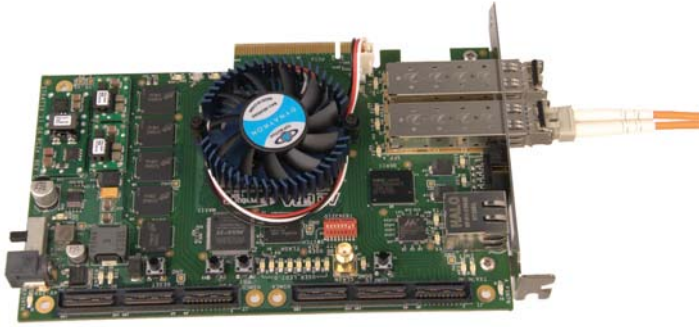

Fig. 5: A network card as used by TTTech for testing.

TTEthernet defines basic building blocks that allow the transparent integration of the time-triggered services on top of message-based communication infrastructures such as standard Ethernet. For this, TTEthernet defines a novel application of the transparent clock mechanism that enables the concept of the permanence point in time, which allows re-establishing the send order of messages in a receiver:

- Application of transparent clock mechanism: all devices in the distributed computer network that impose a dynamic delay on the transmission, reception, or relay of a synchronization message add this dynamic delay into a dedicated field in the synchronization messages used for the synchronization protocol.
- Novel precise calculation of the permanence point in time: the application of transparent clock mechanism allows a precise re-establishment of the temporal order of synchronization messages. In a first step the worst case delay is calculated off-line. In a second step, each synchronization message is delayed for "worst case delay minus dynamic delay" upon reception of the synchronization message, where the dynamic delay is the delay added to the synchronization message, as the synchronization message flows through the communication channel. This point after the reception point in time will be called the permanence point in time.

For fault-tolerant algorithms in general, and fault-tolerant synchronization algorithms in particular, the message send order is of highest importance. The re-establishment of the send order of synchronization messages is required for any fault-masking synchronization protocol that ensures synchronization of local clocks in a distributed computer network.

### Safety and Fault Tolerance

A high level of safety is provided by the time-triggered method of TTEthernet, which detects failures and irregularities in the network and certain systems. Additional measures need to be taken to achieve maximum safety, availability and fault tolerance.

TTEthernet networks can be set up with multiple redundant end systems, switches and segments. Thus the system will remain in operation even if faults occur. Redundant network paths are always used in fault-tolerant TTEthernet systems so that the failure of a single system or messages can be tolerated without affecting the application. If multiple redundancy is implemented, multiple faults can be tolerated. It is important that the entire system remains in operation without interrupts under the same temporal conditions as defined before.

TTEthernet allows the integration of guardians in switches and end systems. Guardians check if the communication on the network works in compliance with the predefined parameters. If faulty systems block network segments, the guardian disconnects the network segment or port. Multiple redundant guardians can be implemented to meet the highest safety requirements).

### Conclusion

TTEthernet enables time-triggered communication over Ethernet networks in all application areas. The network provides all necessary mechanisms for applications as diverse as classical web services and time-critical and safety-critical control system in airplanes. Existing networks can be extended step by step using TTEthernet-capable switches and end systems without the need to change existing applications and end systems. Reducing network solutions to established and recognized Ethernet standards opens up saving potentials that secure major advantages in competitive markets. 📌

# TTTech

#### Contact:

**TTTech Computertechnik AG**  
 Schoenbrunner Strasse 7  
 A-1040 Vienna, Austria  
 Tel.: +43 1 585 34 34-0  
 Fax: +43 1 585 34 34-90  
 E-mail: [office@tttech.com](mailto:office@tttech.com)  
 Web: [www.tttech.com](http://www.tttech.com)

# Joost may know it

## Hoe werkt een plasmabol?

**Author: Benjamin Gardiner**

De plasmabol is een voorwerp dat in het kader valt van fascinerende objecten, net als de lavalamp. Kenmerkend aan deze objecten is dat je er uren naar kan staren met de vraag hoe ze nou werken. Vandaag zal ik jullie vertellen hoe één van deze objecten werkt, namelijk de plasmabol.

Je hebt vast gezien hoe in een plasmabol alle bliksemflitsen naar de buitenkant van de bol gaan en hoe je dit effect kan verstoren door je hand op het glas te leggen. Als je dit doet gaan de bliksemflitsen naar je hand toe, maar waarom?

Een plasmabol is opgebouwd uit drie verschillende onderdelen. De eerste is de elektrode in het midden van de plasmabol en dient voor het opbouwen van het potentiaalverschil. Het tweede onderdeel is het medium waar de bliksemflitsen zich doorheen bewegen, dit is meestal een edelgas maar een gas als stikstof kan ook. De reden waarom lucht niet geschikt is, komt doordat lucht geen duidelijke vonken maakt en het potentiaalverschil een stuk hoger moet zijn dan bij edelgasen. Het derde deel van de plasmabol is de glazen bol om de plasmabol. Deze dient simpelweg voor het vasthouden van het gas.

Wat is een plasma? Plasma wordt ook wel gezien als de vierde aggregatietoestand. Plasma ontstaat door atomen op te warmen tot heel hoge temperaturen. Daardoor beginnen de atomen met grote snelheden te bewegen zodat, telkens als ze botsen, de elektronen weggerukt worden uit de atomen. Zodoende bestaat plasma uit positief geladen ionen en de elektronen die van de atomen zijn losgekomen. Dit kan ook gerealiseerd worden door een hoog potentiaalverschil aan te brengen waardoor de elektronen van de kernen worden los getrokken.

Wat is nou de reden dat die bliksemflitsen naar je hand toe gaan als je deze op het glas legt. Dit komt doordat de ionen die zijn ontstaan bij het ioniseren van het gas nieuwe elektronen zoeken. Door jouw hand op de glazenbol te leggen creëer je een aardpunt waar nieuwe elektronen vandaan kunnen komen. Zo ontstaat er door je lichaam naar aarde een stroom, deze voel je niet omdat hij zeer klein is. De ionen zoeken nieuwe elektronen en worden daardoor aangetrokken naar het aardpunt wat in dit geval jouw hand is, dit zie je vervolgens als bliksemflitsen die in de richting van jouw hand bewegen. ⚡

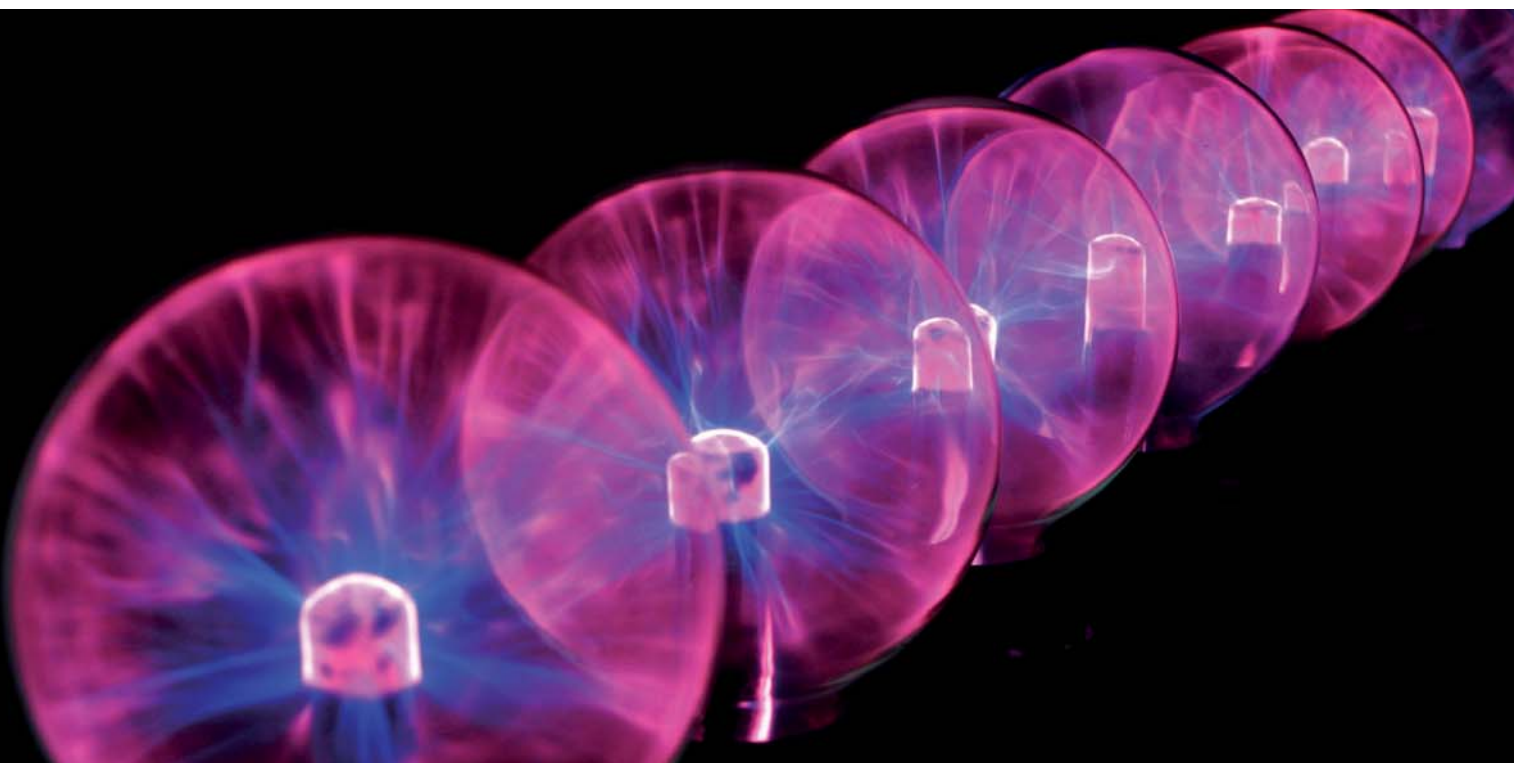

Plasmabollen

**HIER INVOEGEN: PAGINA 35  
NAVIGON + PINEWOOD.PDF**

# Nuna5: What went wrong?

Author: Rico van Dongen



The Nuon Solar Team and their famous car the Nuna had a great tradition of winning the World Solar Challenge in Australia. Four times in a row the car was faster than all the other solar cars. This year, however, it was different. Some headlines claimed we lost first place, others said we won second. Because of all the hard work our team put in the car, I would agree with the second one. We had a great fight with the Michigan solar car and managed to stay in second position. This year's winning car, from Japan, was way ahead of us from the first day on. So, what went wrong with the legendary Nuna? Why was the fifth victory out of our reach?

## Before the race

Three weeks before the race in Darwin, Australia, the car was getting into shape and testing went well. We could finally start to change our team from a group of engineers to a well-oiled racing team. At the point where none of us expected it, it all went terribly wrong. The rear tire blew and Nuna became unstable. The driver could no longer control the three wheeled vehicle because the most important one of the three was no longer there.

Nuna went off-road with a speed of approximately 100km/h which resulted in a spectacular crash. Large parts of the solar panels were damaged, most of the suspension was gone and, of course, a lot of bodywork was ripped away. Luckily most of the structural parts were still intact and probably the most important part, the driver, could get out without a single scratch. After an analysis of what had happened we pulled the team back together and started the rebuild. With a lot of support from our sponsors we managed to get the car running again within two weeks. We could finally start testing again but we did lose a valuable 2 weeks of race preparations.

Figure 1: The Nuna5 after crashing.



## Four days of trouble

During the race the electronics of our precious lady Nuna performed a bit disappointing. A lot of systems that we used for monitoring the car stopped working, or only worked a part of the time. The most important issue was a failing MPPT (Maximum Power Point Tracker). Even when we replaced the tracker with a fresh one it would stop working within an hour. And, most surprisingly, the old one worked fine in the test environment. It took us four days to find the problem. What was the cause of this stupid problem I will discuss later. First I will go into the details of the tracker.

## IV Curve

The first question you might have is why we would need an MPPT between the solar panel and the battery of the car. Well, as the name suggest, it is to get a maximum amount of power from the sun. This all depends on the voltage curve of solar cells.

When a photon hits a solar cell an electron is kicked out of the semiconductor material. The intensity of the light determines the flow of electrons. If a constant amount of photons per second hit the material, a constant amount of electrons will be kicked out of the cell. This behavior can best be modeled with a current source.

To get the maximum amount of power out of a current source we should keep the voltage as high as possible. However if we do this with a solar cell we will suffer from recombination

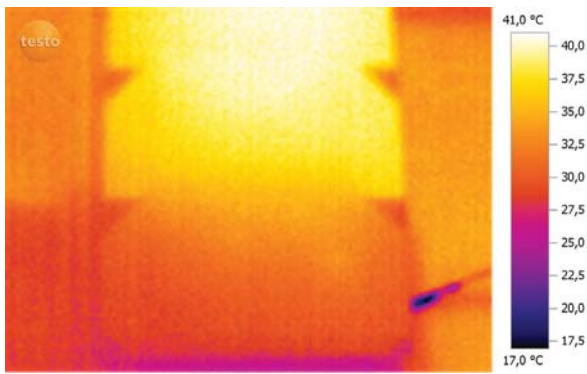

Figure 2: Thermal image - normal.

and the cell starts dissipating most of the energy on its own. With some cells you can even see this effect when the cell is left in the sun without a load. Suddenly small red lights appear on these cells. Also hotspots can appear that sometimes become so hot that they burn trough the cell (Figures 2&3).

In figure 4 an IV curve (blue line) of an arbitrary silicon solar panel is given. The red line in this figure shows the multiplication of voltage and current, the PV curve. It is clearly shown that the maximum amount of power can be drawn from this panel by adjusting the output voltage to the point where it starts going down. This lower voltage prevents the electrons from recombining with their holes and makes sure that all the power goes to the battery.

## MPPT

The maximum power point (MPP) of a solar cell is constantly shifting due to changing weather conditions. When the sun intensity is low the MPP shifts to a lower voltage. Of course a battery can only be charged when the voltage is higher than its own voltage so there need to be some sort of conversion. That is why the tracker is basically an adjustable boost converter. A special tracking algorithm tests certain point on the IV curve and makes sure the converters input voltage is near the MPPT. These testing points are the yellow dots in figure

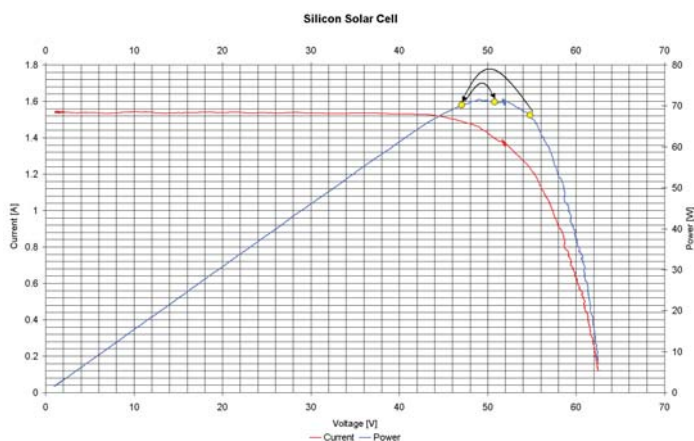

Figure 4: IV-curve.

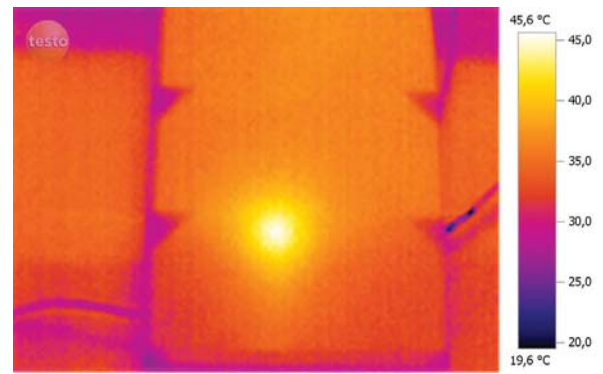

Figure 3: Thermal image - hotspot.

4. When the intensity of the sun changes the MPPT has to be adjusted to the new intensity. Compared to the tracking algorithm these changes are slow so by simply trying different points the converter goes back to the MPP. Some trackers are also able to detect the slope of the PV curve and thereby knows if it has to increase or decrease its input voltage.

## Failing connections

So, now we know what the tracker should do. But why did it stop working during the race? Probably the cause was in the mounting of the board. One support had some minor fabrication errors that caused some tension on the PCB of the tracker. After a while the board would heat up and expand a bit. This expansion caused some extra tension that resulted in a broken contact. This stupid problem caused us about one quarter of the total solar input power. This means that we came in second with only three quarters of the energy. Quite an achievement if you ask me.

## Better luck next time

Of course we all learned a lot during the design and build phase of the Nuna project, but we probably learned the most during the 5 days of intense racing. I am sure that the next team will put some special care in the supports of all the PCB's and improve the design even more. Then, the Nuna6 will be able to win the race again and maybe even break the world record. This record is still in the hands of Nuna3 which could drive up to 103kph average thanks to the more flexible regulations.

To make sure the new team knows all the details about Nuna we now started a special course. Under the cover of the course 'sustainable mobility and transport' (AE4-T39), we now go through the complete design. If you would like a taste of the Nuna race spirit and know more about the design of Nuna5 feel free to follow this course. But of course, if you really want to know how amazing it feels to design, build and race a solar car you will have to join the Nuna6 team. 🚗

# Circuit Boding

## FM bug transmitter

Many people have their interest in electronics start with radio. As much as radio is taken for granted by most people, the idea of sending information through the through the air at the speed of light remains enticing to anyone who thinks about it for longer than a few minutes. As such, we submit to you this simple yet effective FM transmitter.

**Author: Ben Allen**

Everybody who has seen a James Bond movie, or anything involving spying of any sort, has heard of the concept of a bug. A small electronic device is placed in a person of interest's room, and the agents in the other room can listen in on what's going on. Evidence is gathered, and the story can move on.

Of course, in reality things are a little different. The microscopic devices used in Hollywood are slightly more advanced than what we can achieve on our breadboards. Unless you have a very steady hand or access to an smd soldering oven you're not going to be able to replicate the miniature devices seen in the movies.

### Legal concerns

There are a few less frivolous concerns when it comes to radio circuits. Radio frequency transmissions are strictly regulated and simply transmitting on AM/FM bands is illegal - something that has shut down many decent pirate radio station in the past. The reason for this is simple: you need a license to use a certain frequency - and these licenses are sold at auction. Because commercial radio stations are also interested in acquiring a license to transmit, these become incredibly expensive. As such, transmitting on AM band is illegal in the Netherlands. Luckily, there is a provision in the law for

low-power FM devices, for instance to listen to your iPod in the car without having to fit a new stereo system.

Please note that the power allowed for these devices is severely limited. The circuit we have featured has a range of about 20-30 metres, but more powerful devices step over the low-power boundaries and as such are not permitted.

### Listening in

Before we can even start to think about transmissions, we need something to transmit. In our case, we're looking to transmit audio. In figure 1 we have a simple one-transistor amplifier that takes

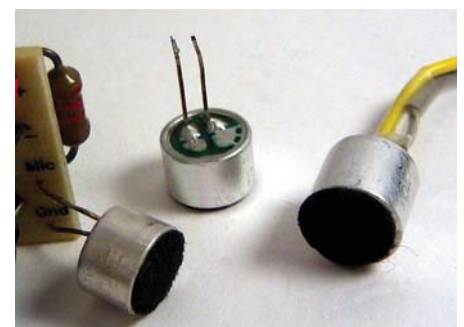

Figure 2. A number of electret condenser microphones.

its input from a condenser microphone. A condenser microphone (figure 2) is a special type of microphone in which the diaphragm (the moving part of the microphone) acts as one of the plates of a capacitor. As the diaphragm moves, the capacitance changes.

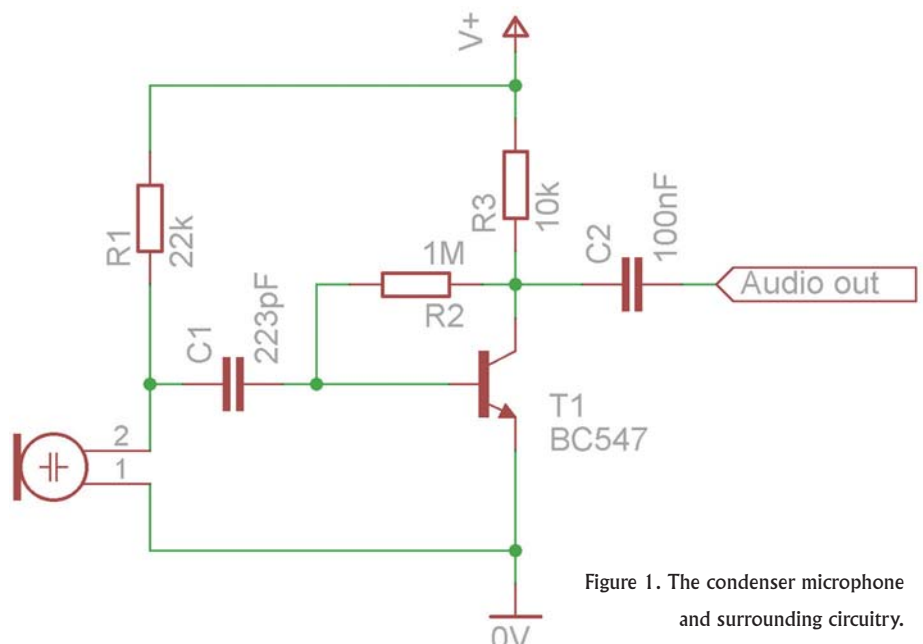

Figure 1. The condenser microphone and surrounding circuitry.

## Part list:

**R1: 22k**  
**R2: 1M**  
**R3: 10k**  
**R4: 47k**  
**R5: 470**

**C1: 223pF**  
**C2: 100nF**  
**C3: 102pF**  
**C4: 5.6pF**  
**C5: 27pF**  
**C6: 6-45pF trimmer**

**L1: 1 $\mu$ H**

**ANT1: simple antenna**

**T1, T2: BC547**

to 90MHz and attempt to receive a signal whilst adjusting C6.

Because the capacitance of T2 is in the same order of magnitude as C6, the idea is that as the transistor amplifies the input, this capacitance influences the oscillator, causing the frequency to change - Frequency Modulation.

This is presented, once again through a DC filtering cap, to the antenna, which broadcasts the signal.

### Power supply

The power requirement of the circuit is very simple, as shown in figure 3. A 3-5V supply is enough, so a series connection of 3 AAA cells can power the circuit easily. The large 470 $\mu$ F capacitor C7 provides smoothing in the case of external power supplies.

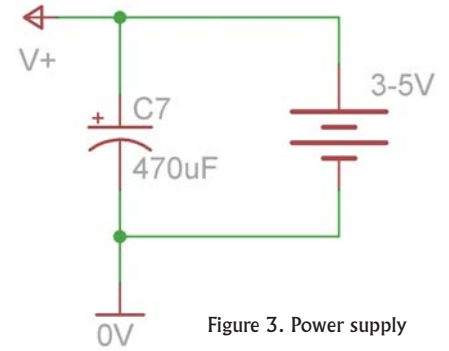

Figure 3. Power supply

### Final Notes

Making an FM transmitter out of discrete parts is notoriously unreliable. A simpler, but less interesting way is to use ICs to provide modulation, as all they require is an input signal and an antenna, and in some cases a crystal for the oscillator. If your goal is reliability as opposed to experimentation, an IC such as the MC2833 or the MAX2606 might be more to your liking. [+](#)

### Using a microphone

The circuitry in figure 1 is fairly self-explanatory. One thing to take into account is that the condenser mic needs a voltage to be applied across the device for it to operate. Unlike dynamic microphones, condensers don't create an output by themselves. We are, in essence, measuring and amplifying the change in the device's behaviour as opposed to measuring an output from the device itself.

### Turning it into radio

The interesting stuff happens in figure 4. First of all, note that the input does not have a DC filtering capacitor. This is because the microphone amplifier circuit already features this capacitor, C2. If you intend to use the circuit to broadcast something other than the output from the microphone you should add the 100nF capacitor in series with the input.

C6 and L1 provide an oscillator, the frequency of which can be adjusted with C6. When tuning the circuit, tune your radio

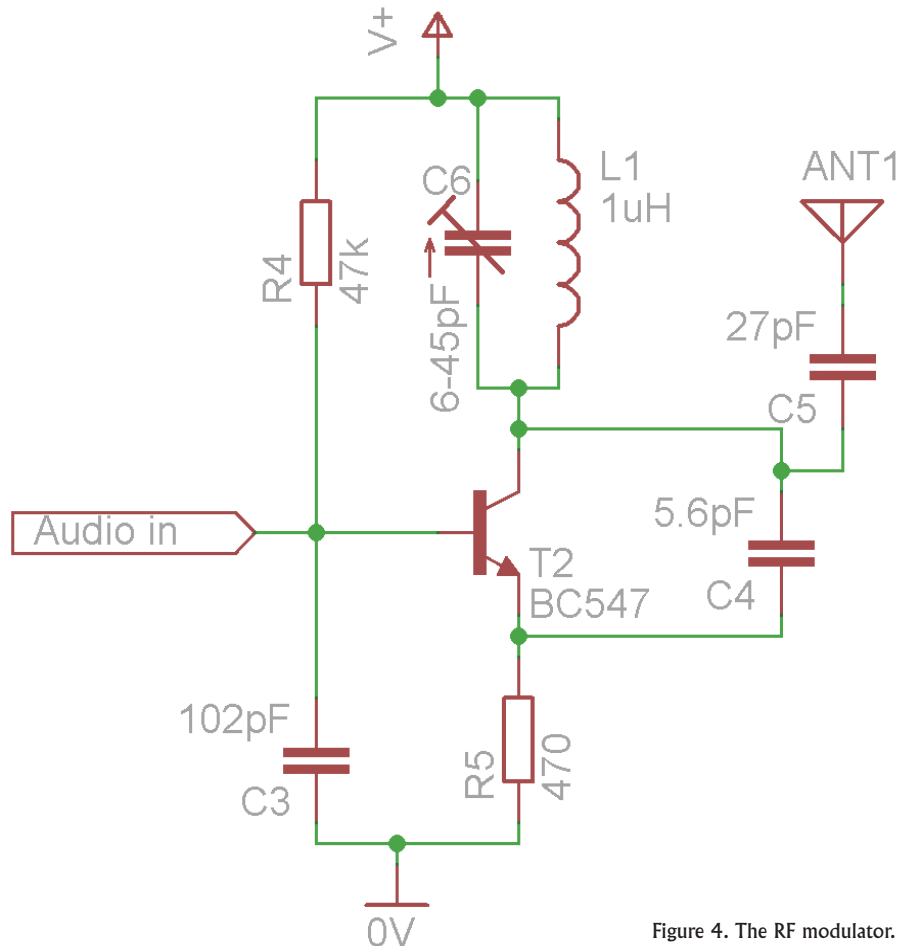

Figure 4. The RF modulator.

# Per elektrische scooter naar Kopenhagen

Auteur: Frank Teunisse



Via via werd ik gevraagd of ik op een elektrische scooter namens de gemeente Delft wilde deelnemen aan de Road to Copenhagen. Als vierdejaars student Electrical Engineering en Bestuurder van de Electrotechnische Vereniging is dit een vraag waarop maar één antwoord mogelijk is: ja! Niet alleen is het een geweldige uitdaging, ook is het een buitenkansje om de Elektrotechniek weer eens voor het voetlicht te halen.

Toen ik mij meer ging informeren over de actie, las ik dat een groep van wel honderd jongeren op scooters naar Kopenhagen zou gaan rijden, om daar tijdens de klimaatconferentie afgelopen december een manifest aan de wereldleiders aan te bieden.

Aanvankelijk was ik daarom bang dat ik met een stel hippies naar Kopenhagen zou gaan. De groep was echter erg divers. Zo waren er studenten bedrijfs- en bestuurskunde, internationale betrekking en duurzame ontwikkelingen. Ik was een van de weinige technische studenten. Ondanks deze ogenschijnlijke cultuurbarrière zijn we al snel een hechte gezellige groep geworden. Het hoofddoel

Samen met honderd andere studenten reed de Commissaris Onderwijs van de ETV, Frank Teunisse, de 'Road to Copenhagen' om tijdens de klimaatop aandacht te vragen voor duurzaam vervoer.



van de tocht was, naast het promoten van duurzaam vervoer, het aanbieden van een manifest aan de wereldleiders die op dat moment aan de klimaatop deelnamen.

De scooter waar ik op reed werd gesponsord door Delft en was onder handen genomen door het Delftse bedrijf Epyon. Daarom kon deze in een half uurtje volgeladen worden, in tegenstelling tot de andere negentig scooters. Voor de gemeente Delft was deze tocht een goede manier om hun betrokkenheid bij duurzame ontwikkelingen te tonen. Per dag werd er vier uur gereden. Geheel conform de tijd van het jaar was het rijden erg koud. Gewapend met thermo-ondergoed, een fleecetrui en een dikke winterjas reed ik in vijf dagen de eerste etappe, van Den Bosch naar Osnabrück.

Wanneer we niet op de scooter zaten, werden we vermaakt met lezingen, workshops of excursies. Deze dienden als inspiratie voor het manifest dat we aan het einde van de tocht in Kopenhagen aan de wereldleiders hebben aangeboden. In dit manifest staan twaalf tips om een duurzamere samenleving te verwezenlijken. Zo kwam mijn groepje met het idee om het voor consumenten duidelijker te maken dat zuinigere producten op de lange duur goedkoper zijn. In de supermarkt staat verplicht op







Naast al deze serieuze activiteiten werden we goed verzorgd; iedere dag, soms zelfs al in de lunch, stond er een heerlijke warme maaltijd op ons te wachten, ter compensatie voor de koude ontberingen van die dag. Alsof dat niet genoeg was, werd de dag afgesloten met een goed feest. Echter, na een korte nacht in een jeugdherberg moesten we voor acht uur al weer klaar staan voor de volgende dag.

Het meest indrukwekkend vond ik zonder twijfel het meerijden in een Tesla Roadster. De Tesla is een elektrische sportauto, vernoemt naar uitvinder en Electrotechnisch ingenieur Nikola

alle producten hoeveel calorieën een portie bevat. Wanneer er op een lamp verplicht staat aangegeven hoeveel deze per jaar kost, zijn mensen veel eerder geneigd een duurdere, maar in gebruik goedkopere, LED-lamp te kopen.

De meest interessante lezing was die van Michael Braungart, Hoogleraar Cradle-to-Cradle aan de Erasmus Universiteit Rotterdam. Zijn idee is dat energie besparen alleen tot gevolg heeft dat men minder slecht is voor het milieu. Waar men vanuit zou moeten gaan, is dat je iets positiefs aan het milieu toevoegt, in plaats van zo min mogelijk negatiefs. Zo heeft Braungart meegewerkt aan een duurzame wolkenkrabber in de woestijn, die meer energie en water opbrengt dan de inwoners zelf gebruiken.

Tesla (1856 – 1943). Met recht heeft deze wagen de titel 'sportauto', aangezien de '0 tot 100km per uur' al in 3.7 seconde gehaald kan worden. En dat deed hij dan ook. Het voelde als in een achtbaan, ik werd helemaal in mijn stoel gedrukt. Het piepen van de banden was daarbij het enige wat ik hoorde, want de motor produceert slechts een miniem gezoem.

Al met al ben ik zelf niet veel "groener" geworden van deze ervaring. Ik ben me wel veel meer van bewust van het klimaatprobleem en ik geloof nu wel dat dat ook echt een probleem is. Momenteel wachten consumenten en het bedrijfsleven op elkaar om te investeren in bijvoorbeeld elektrisch vervoer. Aan zet is, wat mij betreft, dan ook de overheid. Zij kan zowel de burgers als het bedrijfsleven stimuleren te investeren in duurzame producten. Deze reis heeft mij in ieder geval kunnen overtuigen dat elektrisch vervoer een volwaardig alternatief voor vervoer op brandstof is. Nu is het wachten op de grote massa. 🚗



# Gadgets

## Tiny Generators Charge Up From Random Vibrations In the Air

What's an easier green power source to acquire than sun or wind? Random ambient vibrations, that's what. And that's exactly how some new generators juice up.

The devices, created by researchers at the University of Michigan, aren't going to be powering your cars any-time soon, but they'll be able to gather enough energy to power watches, pacemaker or wireless sensors.

The vibrations they pick up are from things like traffic on bridges, machinery operating in factories or you swinging your arms around.

The researchers have built three prototypes and a fourth is forthcoming. In two of the generators, the energy conversion is performed through electromagnetic induction, in which a coil is subjected to a varying magnetic field. This is a process similar to how large-scale generators in big power plants operate.

The latest and smallest device, which measures one cubic centimeter, uses a piezoelectric material, which is a type of material that produces charge when it is stressed. This version has applications in infrastructure health monitoring. The generators could one day power bridge sensors that would warn inspectors of cracks or corrosion before human eyes could discern problems.

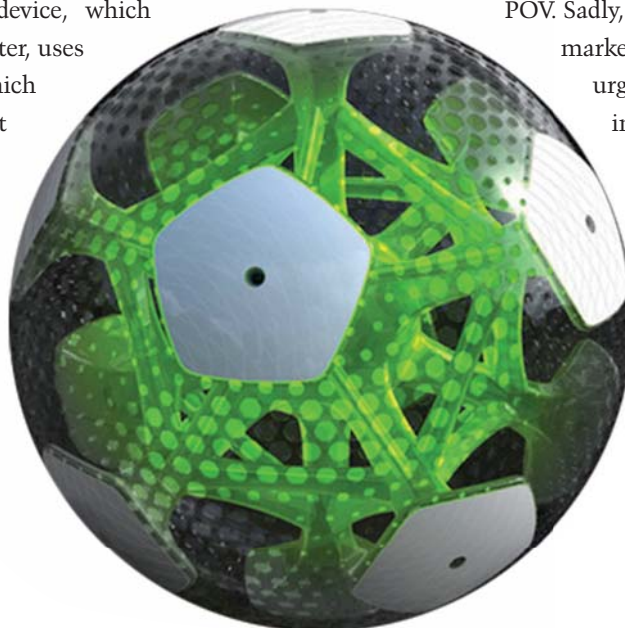

## Conceptual 'CTRUS' football gets loaded with sensors, don't need no pump

We've heard of soccer balls that play a tune when kicked, sure, and we're pumped to see the World Cup in 3D, but it's not often that someone comes up with a serious technological makeover for the sport that's nearly as old as

life itself. CTRUS, however, is just that - a theoretical revolution in soccer that begins with the all-important ball.

To start with, a reinforced elastic structure means that CTRUS doesn't require any air. (So long, pump.)

Next, GPS and RFID chips keep track of the ball's position at all times, and tell it to light up in different colors when it scores a goal or is accomplice to a nefarious violation. (Farewell, referee.) Last but not least, the sphere itself will report back with accelerometers that measure the ball's kick force and travel speed, and a camera that could (with magical software stabilization, of course) actually film action from the ball's own

POV. Sadly, the ball is just a concept from an undercover marketing agency, but since we're dreaming, we urge its creators to add a second camera. Just imagine just how immersive it would be to have your face booted in at 130km/h in glorious 3D. Or, just peek the concept videos after the break.

Source: [www.gizmodo.com](http://www.gizmodo.com)

# GPU: brute kracht inzetbaar voor meer dan alleen beelden?

De GPU (Graphics Processing Unit) in een moderne pc is een waar rekenmonster. Bij het produceren van een vloeiende stroom beelden voert de GPU meer berekeningen per seconde uit dan de processor (CPU). Maar in de praktijk blijkt het niet eenvoudig GPU's in te zetten voor andere toepassingen.

## Auteur: Technolution B.V.

Gedreven door ontwikkelingen in de 3D-gamingmarkt zijn zeer snelle grafische processors ontwikkeld. Bij de eerste grafische toepassingen rekende de CPU van de pc pixel voor pixel het weer te geven beeld uit. Daarna werd pixel voor pixel het beeld naar de videokaart gestuurd. Vervolgens gaf de videokaart slechts de pixels weer. Dit is een zeer rekenintensieve klus, zeker als dit bijvoorbeeld in een 3D-game bij 30 frames per seconde moet gebeuren met een resolutie van 1920 x 1200. In de jaren negentig kwamen steeds krachtigere videokaarten voor de consument op de markt en kreeg de videokaart zijn eigen processor, de GPU. In plaats van pixel voor pixel de videokaart aan te sturen worden objecten en instellingen aangeleverd, zodat deze aparte processor zelfstandig werk kan verrichten naast de CPU.

## Standaardisatie

In de 3D-gaming, een consumentenmarkt, worden zeer grote volumes van deze processors verkocht. Omdat de producenten van de GPU's en de games verschillende bedrijven zijn, ontstond de noodzaak tot standaardisatie van de interfaces (API's). De belangrijkste 3Din-

terfacestandaarden zijn DirectX/Direct3D en OpenGL. In de praktijk komt het erop neer dat de GPU-producenten strikt de gespecificeerde functionaliteit van deze 3D-interfaces (API's) volgen. ATI (nu AMD) en NVIDIA zijn bekende producenten van GPU's. De kern van 3D-spellen is dat een virtuele 3D-wereld op het scherm wordt afgebeeld vanuit het perspectief van een (virtuele) speler, met een snelheid van bijvoorbeeld 30 frames per seconde. Dit wordt gerealiseerd door een hele reeks bewerkingen in een vaste volgorde uit te voeren. Dit proces heet een rendering pipeline.

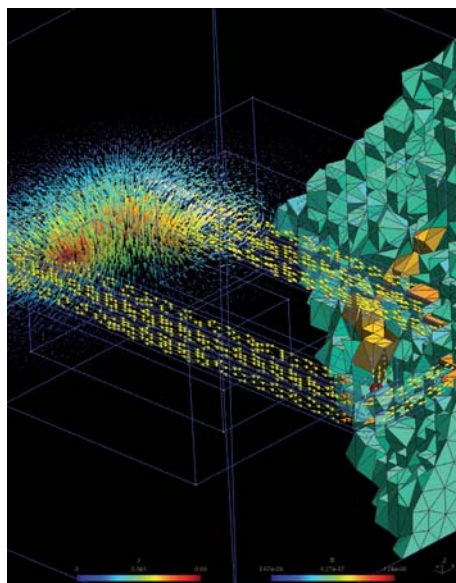

## Geschiedenis

In de jaren negentig kwamen steeds krachtigere videokaarten voor de consument op de markt. En een steeds groter deel van de rendering pipeline werd in hardware uitgevoerd. De bewerkingstappen in de rendering pipeline zijn de zogenaamde shaders. Bijvoorbeeld een vertex shader voegt bepaalde 3D-effecten toe aan objecten, een geometrieshader genereert nieuwe objecten vanuit al gedefinieerde objecten en een pixelshader berekent de kleur van een pixel. Een belangrijk nadeel was dat met het vastleggen van de specifieke shaders in hardware ook de rekenkracht per shader vast lag. Dit terwijl verschillende spellen verschillende eisen stelden aan de verdeling van de rekenkracht tussen de verschillende shaders. Relatief recent is er als onderdeel van de DirectX-standaard een Unified Shader Model gespecificeerd. Het betreft een processormodel dat uitgerust is met een instructieset die geschikt is voor de functionaliteit van alle verschillende typen shaders. Het voordeel van dit concept is dat per stap van de rendering pipeline de volledige rekenkracht aangewend kan worden en programmeerbaar is. Met dit nieuwe type grafische processor is ook de eerste praktische mogelijkheid ontstaan om de GPU voor ander rekenwerk in te zetten.

## Rekenkracht moeilijk te temmen

De hedendaagse GPU beschikt over een enorme rekenkracht. Hij kan tot wel 30 keer meer floating pointberekeningen verwerken dan een reguliere CPU (zie figuur). Dat klinkt geweldig: zoveel meer rekenkracht in een processor voor globaal dezelfde prijs. Dat wil iedereen wel. Maar als iets te mooi klinkt om waar te zijn, dan is het dat vaak ook. Aan een 'alternatief' gebruik van een GPU, anders dan als grafische kaart in een pc, kleven de nodige mitsen en maren. Het rekenkundige probleem moet goed passen op de architectuur van een GPU, evenals de floating pointprecisie en het is »

praktisch niet mogelijk om een GPU te combineren met een andere hardwarearchitectuur dan die van een pc.

## Dieper in de techniek van de GPU

Is het verhaal dan klaar met de conclusie dat de GPU elk jaar betere beelden maakt, maar een plaatjesmachine is en blijft? Zo zwart/wit liggen de zaken niet. In bepaalde gevallen en onder strikte voorwaarden zou een GPU als alternatief kunnen dienen voor ander zwaar rekenwerk dan alleen grafisch werk. Daarvoor moeten we iets dieper in de techniek duiken. Een GPU is een parallelle processor: hij voert zeer veel parallelle bewerkingen uit. Dat is bijvoorbeeld te zien aan de brede geheugenbussen, tot wel 256 bits. Ter vergelijking: de CPU is nog niet zo lang geleden van 32 naar 64 bits gegaan. Een GPU werkt dus met veel meer data tegelijk. Maar het ontwerp is bedoeld voor eenrichtingsverkeer: er komt een brok data binnen met elementaire beeldinformatie, voor elke pixel berekent hij het een en ander, vervolgens stuurt hij dat er aan de andere kant uit richting het beeldscherm. Een GPU is slecht in keuzes maken, zoals in het doorlopen van typische "if ..., then ..., else ..." softwareconstruc-

ties. Daar wordt hij traag van. Een GPU is juist gebouwd om voor alle parallelle paden hetzelfde te doen. Dat heet single instruction, multiple data (SIMD). Er is een instructiedecoder en een hele groep executie-units. Zodra er een keuze komt, kan die maar voor een executie-unit gelden en kunnen de anderen niets effectiefs doen. Een gewone processor is veel beter in het oplossen van if-then-else-problemen. Die kan slim door een reeks van voorwaarden en afhankelijkheden heen slalommen en zich veel rekenwerk besparen, als een skiër die in de afdaling continu kiest en stuurt om de snelste weg te vinden. Een GPU is als een roeiboot met bijvoorbeeld acht roeiers die tegelijkertijd samen een doel proberen te bereiken. Als elke roeier een ander parcours zou moeten varen, dan kan dat alleen maar door acht parcoursen achterelkaar te varen met telkens één roeier aan het werk. Een GPU is dus goed in het parallel verwerken van rekenkundige bewerkingen volgens vaste formules.

## Berekeningen aansturen met API

Als een GPU gebruikt gaat worden, moet dat gebeuren met speciale instructies, die bij elk merk GPU kunnen ver-

schillen. Hierbij zijn de standaard API's niet bruikbaar. Het is dus hard nodig om toegang tot de GPU's te standaardiseren, zodat de functies die moeten worden uitgevoerd op een redelijk abstract niveau kunnen worden aangeboden. Op dit moment zijn de belangrijkste twee: CUDA van NVIDIA en de merkonafhankelijke variant OpenCL (Open Computing Language). OpenCL is initieel gedefinieerd door Apple Inc., maar is door hen via de Kronos Groep tot een open standaard gemaakt. Door deze API's te gebruiken kunnen de ingewikkelde details van een GPU worden beheerst en kan de programmeur zich richten op het onderhavige probleem. Ook zullen door standaardisatieprogramma's (bv. Matlab) er bibliotheken ter beschikking komen met GPU-ondersteuning voor veel voorkomende problemen, zodat niet iedereen opnieuw het wiel hoeft uit te vinden.

## Rekenkracht GPU anders aanwenden

Door de genoemde API's is, zoals eerder aangegeven, het mogelijk om goed passende rekenkundige problemen, zonder uitvoer naar een beeldscherm, met succes sneller op een GPU uit te voeren dan op een CPU. Gedacht moet worden aan o.a. matrixberekeningen en Fouriertransformaties, zoals die bijvoorbeeld voorkomen in ruimtelijke problemen als 3Dsimulaties van stromingen of elektromagnetische velden. Dit zijn verschijnselen die zich laten analyseren door de wereld in kleine vakjes of kubusjes te verdelen om per vakje een natuurkundige vergelijking op te lossen (ook wel de eindige elementenmethode genoemd). Het oplossen van deze vergelijkingen vergt heel veel 'simpele' rekenstappen op een grote dataset, maar ook andere grootschalige berekeningen (vooral floating point) en beeldgeneratie voor de professionele en wetenschappelijke gebieden. Voor dit soort toepassingen heeft NVIDIA een professionele GPU ontwikkeld onder de naam Tesla. Een onderzoe-

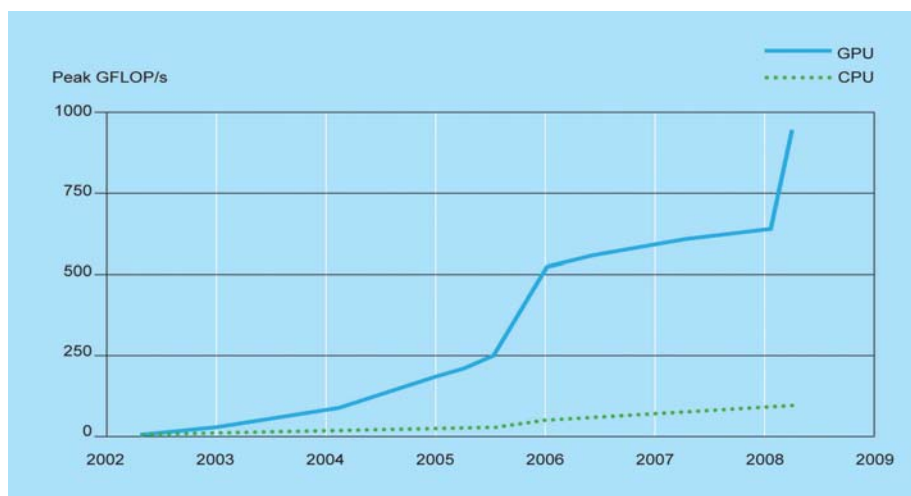

Figuur 1: Droomscenario: GPU versus CPU

Optimale inzet van een GPU voor beeldbewerking kan bovenstaande curve opleveren (met fors meer MIPS voor de GPU dan bij de CPU). Buiten die specifieke grafische toepassing is een GPU beperkt. Het draaien van niet-grafische toepassingen op een GPU zou een ander plaatje laten zien: de performance stort in tot onder de CPU-curve.

ker heeft zo voor een relatief bescheiden bedrag een desktop die qua rekenkracht kan wedijveren met een supercomputer.

### GPU in embedded systemen?

Voor professionele technische toepassingen is een GPU alleen maar bruikbaar in zijn natuurlijke habitat: op een grafische kaart, ingebouwd in een pc, met standaard software. Mochten GPUchips al los verkrijgbaar zijn, dan nog zijn ze moeilijk in embedded systemen in te passen. Het probleem moet passen bij de architectuur van de chip, de chip moet passen in het systeem en het businessmodel moet kloppen. Zo heeft de GPU voor zijn inzetbaarheid bij grafische toepassingen een korte levensloop en is daardoor slecht verkrijgbaar op de lange termijn. De professionele embedded wereld is vrijwel altijd beter uit met een FPGA. Die zijn wel lang genoeg leverbaar. De keus in FPGA's is enorm: voor elk denkbaar probleem is wel een specifieke FPGA te vinden. Deze zijn ook nog

eens uiterst flexibel. De ontwikkelaar kan namelijk zelf de balans kiezen tussen parallel en serieel, tussen data load en rekenkracht. Soms zijn er niet zoveel afzonderlijke berekeningen nodig, maar moet het wel op 10Gb datastromen gebeuren, zoals in een hoge resolutiecamera. Die genereert een bulk data die eerst wordt bewerkt voordat een pc er iets mee kan. Misschien zou dat met een GPU kunnen, maar voor bewerkingen in het embedded domein kiest Technolution er altijd voor om de datastroom met een FPGA te bewerken. Juist vanwege voren genoemde zaken.

### Toekomst GPU

Een van de grootste beperkingen van vandaag in het parallel rekenen is de doorvoersnelheid van het geheugen. Larabee is de codenaam van een ontwikkeling bij Intel, die een hybride van een X86 CPU en een GPU in een smeedt tot een GPGPU (General Purpose GPU). In dit geval wordt gebruik gemaakt van vele

volwaardige CPU-kernen met SIMD-support en een conventionele cache. Door in de toekomst een CPU- en een Larabeechip te integreren komen beide typen processoren op een plak silicium te zitten en kunnen de verbindingen erg kort en dus snel zijn. Dit geeft veel flexibiliteit en performanceverbetering voor een breder scala rekenintensieve toepassingen. De performanceclaims van Intel worden door de bestaande GPU-specialisten met de nodige scepsis benaderd. Als deze combinatiechip slaagt, zou hij het einde van de losse grafische kaart kunnen inluiden en dus geheel nieuwe toepassingen voor de GPU in beeldbrengen. ☺

Dit artikel is overgenomen uit **Objective 12**, het magazine over innovatie en technologie van Technolution op managementniveau.

Hier invoegen: [pagina45Technolution\\_half.pdf](#)

Auteur: Prof. Dr. Leo Ligthart



## Buitengrenzen van TU Delft

Na mijn bijna 46-jarige carrière (van student tot hoogleraar-directeur onderzoeksinstituut IRCTR) op TUDelft wil ik u deelgenoot maken van mijn persoonlijke ervaringen met TUDelft buitengrenzen.

Wat merk je van TUDelft buitengrenzen als je bezig bent met het afstuderen. Eigenlijk niet zoveel. Je volgt nog enkele colleges, je hebt contacten met je medestudenten, mentor en afstudeerhoogleraar. Dan ga je een baan zoeken. Al snel kom je erachter, dat er TUDelft buitengrenzen zijn. Bij bedrijven waar je solliciteert zitten veelal oud TUDelft studenten (alumni) op belangrijke posities. Alumni bepalen zo de beeldvorming van de TUDelft buitengrens voor de pas afgestudeerde.

Contacten met onderzoeksorganisaties lopen veelal via daar werkende onderzoekers met een ir. titel. Dan blijkt, dat alumni gaarne bereid zijn jou te woord te staan. Tevens wordt snel duidelijk dat meerdere alumni een behoorlijke carrière maken en dat zij met trots de relatie duiden tussen hun positie en de TUDelft opleiding.

Mijn passie is internationaal onderzoek. Al in het begin van de 70-tiger jaren had ik interesse voor internationaal contractonderzoek; laten we zeggen 3e geldstroom onderzoek; alhoewel, termen als 1ste, 2de en 3de geldstroom bestonden toen nog niet. Mijn bevoegdheid tijdens projectonderhandelingen bestond eruit dat indien er problemen waren, ik mijn 'professor-baas' moest bellen. Kortom, er waren weinig beperkingen.

Als hoogleraar heb ik mijn buitengrenzen verder kunnen verleggen wetende dat kennis over een bepaald universitair vakgebied geen grenzen kent. Dankzij samenwerking met geselecteerde sterke internationale onderzoeksteams zijn mogelijke oplossingen van grote maatschappelijke problemen haalbaar. Deze problemen zijn meestal multi-disciplinair en vereisen een leerstoel (ja zelfs een TUDelft) grens-overschrijdende aanpak en de opzet van zogenoemde internationale doorbraakprojecten.

Om mijn multi-disciplinair onderzoek maximaal te faciliteren is het onderzoeksinstituut IRCTR (International Research Centre for Telecommunications and Radar) opgericht. IRCTR kreeg erkenning van het Ministerie van OC&W en werd vereerd met een bezoek van de toenmalige minister Ritzen.

Inmiddels zijn er internationale IRCTR branches en vele samenwerkingsverbanden met bedrijven en universiteiten. Hierdoor kunnen studenten en promovendi, niet alleen uit Delft maar ook van partner universiteiten, participeren in internationale programma's.

Wat is mijn buitengrens: niet de universiteit te Delft of de campus van Delft, maar de partnerinstituten. Als ik nu een werkbezoek breng binnen of buiten Europa zijn er altijd oud-afstudeerders, die in eerdere projecten hebben meegedaan en die het op prijs stellen om blijvende contacten met TUDelft en IRCTR in het bijzonder te onderhouden. Mijn TUDelft buitengrenzen liggen bij al mijn oudstudenten, -promovendi en -onderzoekers, die als ambassadeurs van TUDelft op weg zijn naar de top van wetenschappelijke instituten danwel bedrijven of deze positie reeds bereikt hebben. Zij allen waren eens student en hebben bijgedragen aan de over de grens erkende internationale status van het TUDelft radar- en telecommunicatie onderzoek. ➕

**HIER INVOEGEN:  
PAGINA47ASML.PDF**

**HIER INVOEGEN:  
PAGINA48FARNELL.PDF**